

**M ▲ G E L L A N**™

MG5000 V2.0

MG5050 V2.0

**SP**  
**S P E C T R A**®

SP5500 V2.0

SP6000 V2.0

SP7000 V2.0

**STAY D**™

## Programming Guide



We hope this product performs to your complete satisfaction. Should you have any questions or comments, please visit [www.paradox.com](http://www.paradox.com) and send us your comments.

**P ▲ R ▲ D O X**®  
**S E C U R I T Y S Y S T E M S**

# Table of Contents

Entering Programming Mode .....	2	Communication Programming .....	32
Codes and Panel Reset .....	2	WinLoad Programming .....	36
Hardwired System Planning .....	6	Other Settings and Modes .....	36
Wireless System Planning .....	7	Appendix 1: Ademco Contact ID Report Codes .....	37
Zone Programming .....	9	Appendix 2: Automatic Report Code List .....	39
Programmable Output Programming .....	14	Appendix 3: Data Entry & Display .....	41
User Programming .....	21	Hardware Connections .....	42
Wireless Repeater Programming (MG-RPT1) .....	24	Trouble Display .....	48
Wireless Keypad Programming (MG32LRF) .....	27	Installer Function Keys .....	48
System Programming .....	28	Connecting to WinLoad .....	49
Daylight Savings Programming .....	30	Updating Firmware Using WinLoad .....	49
Partition Programming .....	31		

More detailed information can be found in the *Reference & Installation Manual*, which can be downloaded from our website at paradox.com.

 Warning or important information.	 Suggestion or reminder.	 Quick Menu (see page 3)
---	---	---

## Entering Programming Mode



**IMPORTANT:** *StayD Mode must be disabled in order to enter programming mode.*

1. Press [ENTER]
2. Enter your [INSTALLER CODE] or [MAINTENANCE CODE]
3. Enter 3-digit [SECTION] you wish to program
4. Enter required [DATA]

## Codes and Panel Reset

<b>Installer Code (Default: 0000 / 000000)</b>	The Installer code is used to enter programming mode, which allows you to program everything <u>except</u> user codes. To change the default code, go to section [397] on page 21 and refer to section [701] option [1] on page 28.
<b>Maintenance Code (Default: 1111 / 111111)</b>	The Maintenance code is used to enter programming mode, which allows you to program everything <u>except</u> for user codes and communication settings (sections [395], [397], [398], [815], [816], [817], [910], and [911]). To change the default code, go to section [398] on page 21 and refer to section [701] option [1] on page 28.
<b>System Master Code (Default: 1234 / 123456)</b>	The System Master code can use any arming method and can program user codes. To change the default code, go to section [399] on page 21 and refer to section [701] option [1] on page 28.
<b>Panel Reset</b>	Press and hold the RESET switch for five seconds. When the STATUS LED flashes, press the RESET switch within 2 seconds. However, this will not clear a bus module trouble (see section [955]). To reset the panel to default using section programming (see section [950]).



**IMPORTANT:** *When using an SP Series panel, all wireless sections and options do not apply unless an MG-RTX3 is used in conjunction with the panel.*



**IMPORTANT:** *When using an SP6000 panel in conjunction with an MG-RTX3, all MG32LED and MG10LEDV/H keypads must be versions 2.0 or higher.*

## Zones

Step	Action	Details
1	+ [INSTALLER CODE]	= flash. Programmed zones are lit (button or LED depending on keypad). [MAINTENANCE CODE] may also be used.
2	[ZONE NUMBER]	MG32LRF/MG32LED = 2 digits: 01 to 32 MG10LEDV/H = 1 digit: 1 to 0(10)
3	[ENROLL OR ERASE ZONE]	Wireless zone = open/close cover or press learn/tamper switch. Hardwired zone = Press [ENTER]. To erase a programmed zone, press [SLEEP] for 3 seconds.
4	[ZONE TYPE]	Refer to <i>Entering Programming Mode</i> on page 2.
5	ASSIGN PARTITION [1] and/or [2] + [ENTER]	Assign the zone to one or both partitions and press [ENTER]. By default, all zones are assigned to partition 1. Goes to next available zone.
Notes	Partition 2 status LEDs, display the signal strength of the selected wireless zone (4 LEDs = best signal; 1 LED = weak signal; No LEDs = hardwired panel/keypad zone)	

## Keypad Zone Number Assignment (Keypad Programming)

Step	Action	Details
1	[ENTER] + [INSTALLER CODE]	[ARM] + [STAY] = flash. [MAINTENANCE CODE] may also be used.
2	Press and hold  (3sec)	[ARM] + [STAY] = on.
3	[ZONE NUMBER] + [ENTER]*	MG32LED = 2 digits: 01 to 32 MG10LEDV/H = 1 digit: 1 to 0(10) * To erase a keypad zone number, press [CLEAR], then [ENTER].

## Delays

Step	Action	Details
1	+ [INSTALLER CODE]	= flash. [MAINTENANCE CODE] may also be used.
2		
3	[1] = Entry Delay 1 (sec.) [2] = Entry Delay 2 (sec.) [3] = Exit Delay (sec.) [4] = Bell Cut-Off (min.)	
4	[000] to [255]	Entry/Exit Delay = seconds / Bell Cut-Off = minutes / 000 = default value



## Time and Date

Step	Action	Details
1	+ [INSTALLER CODE]	= flash. [MAINTENANCE CODE] may also be used.
2	+ [5]	
4	[HH:MM]	Enter time. If HH = 13 or more, skip to step 6.
5	[TIME FORMAT]	Enter time format ([1] = 24hr; [2] = AM; [3] = PM).
6	[YYYY/MM/DD]	Enter date.



## Walk Test Mode

Step	Action	Details
1	+ [INSTALLER CODE]	= flash. [MAINTENANCE CODE] may also be used.
2		
3	[6]	Activates or deactivates Walk Test Mode.



## Installer and Maintenance Codes

Step	Action	Details
1	 + [INSTALLER CODE]	 = flash. [MAINTENANCE CODE] may also be used.
2		
3	[7] = Installer Code [8] = Maintenance Code	
4	[CODE]*	Enter 4- or 6-digit code.* To erase a code, press the [SLEEP] key for 3 seconds.
5	[CONFIRM CODE]	Re-enter 4- or 6-digit code.



## WinLoad

Step	Action	Details
1	 + [INSTALLER CODE]	 = flash. [MAINTENANCE CODE] may also be used.
2		
3	[9]	
4	[PHONE #] + [ENTER]*	Enter PC phone # (up to 32 digits) and press [ENTER].* To erase WinLoad phone #, panel ID, and PC password, press the [SLEEP] key for 3 seconds.
5	[PANEL ID]	Enter 4-digit Panel ID
6	[PC PASSWORD]	Enter 4-digit PC Password



## Monitoring Phone #

Step	Action	Details
1	 + [INSTALLER CODE]	 = flash. [MAINTENANCE CODE] may also be used.
2		
3	[1]	
4	[PHONE #] + [ENTER]*	Enter monitoring station phone # (up to 32 digits) and press [ENTER].* To erase monitoring phone #, reporting format, and account #s, press the [SLEEP] key for 3 seconds.
5	[PARTITION 1 ACCOUNT #]	
6	[1] = CID [2] = SIA	
7	[PARTITION 2 ACCOUNT #]	









## Communicator

Step	Action	Details
1	 + [INSTALLER CODE]	 = flash. [MAINTENANCE CODE] may also be used.
2		
3	[2] = Backup Phone # [3] = Personal Phone #1 [4] = Personal Phone #2 [5] = Personal Phone #3 [6] = Personal Phone #4 [7] = Personal Phone #5 [8] = Pager #	
4	[PHONE #] + [ENTER]*	Enter phone # (up to 32 digits) and press [ENTER]. Goes to next phone#, or go to step 5 if [8] = Pager # was selected. To erase a phone number.pager message, press the [SLEEP] key for 3 seconds.
5	[MESSAGE] + [ENTER]	Step 5 for Pager # only. Enter pager message and press [ENTER].

## Cancel Communication

Step	Action	Details
1	 + [INSTALLER CODE]	 = flash. [MAINTENANCE CODE] may also be used.
2		
3	[9]	Cancels all communication with WinLoad.

## PGMs

Step	Action	Details								
1	 + [INSTALLER CODE]	 = flash. Programmed zones are lit (button or LED depending on keypad). [MAINTENANCE CODE] may also be used.								
2										
3	[PGM NUMBER]	MG32LRF/MG32LED = 2 digits: 01 to 16 MG10LEDV/H = 1 digit: 1 to 0(10)								
4	[ENROLL OR ERASE PGM]*	Wireless PGM = Open/close cover. Hardwired PGM = press [ENTER]. To erase a PGM, press the [SLEEP] key for 3 seconds.								
5	[PGM TYPE]	<table border="0"> <tr> <td>1 = Follow Button  or ●</td> <td>5 = Follow Bell</td> </tr> <tr> <td>2 = Follow Button  or ●</td> <td>6 = Follow Arm</td> </tr> <tr> <td>3 = Follow Zone</td> <td>7 = Follow Stay arm</td> </tr> <tr> <td>4 = Follow Alarm</td> <td>8 = Follow Sleep arm</td> </tr> </table>	1 = Follow Button  or ●	5 = Follow Bell	2 = Follow Button  or ●	6 = Follow Arm	3 = Follow Zone	7 = Follow Stay arm	4 = Follow Alarm	8 = Follow Sleep arm
1 = Follow Button  or ●	5 = Follow Bell									
2 = Follow Button  or ●	6 = Follow Arm									
3 = Follow Zone	7 = Follow Stay arm									
4 = Follow Alarm	8 = Follow Sleep arm									
6	If PGM type is 1, 2, 3, or 4 [ACTIVATION DELAY]	1 = Follow	4 = 15 seconds	7 = 5 minutes						
		2 = 1 second	5 = 30 seconds	8 = 15 minutes						
		3 = 5 seconds	6 = 1 minute	9 = 30 minutes						
	If PGM type is 5 Goes to next available PGM.									
	If PGM type is 6, 7, or 8 [1] and/or [2] + [ENTER]	If system is partitioned, select partition(s) and press [ENTER]. Goes to next available PGM.								
7	If PGM type is 1, or 2 [2-DIGIT REMOTE CONTROL #]	01 to 32; 00 = all remote controls. Goes to next available PGM.								
		If PGM type is 3 [2-DIGIT ZONE #]	01 to 32; 00 = all zones. Goes to next available PGM.							
		If PGM type is 4 [1] and/or [2] + [ENTER]	If system is partitioned, select partition(s) and press [ENTER]. Goes to next available PGM.							

# Hardwired System Planning

**IMPORTANT:** Maximum of 3 APR-ZX8 modules.

Serial # Sticker	Description	Path Zone (Entry Point)	Path Zone	Path Zone	Path Zone
Keypad 1/ APR-ZX8					
Keypad 2/ APR-ZX8					
Keypad 3/ APR-ZX8					
Keypad 4/ APR-ZX8					
Keypad 5/ APR-ZX8					
Keypad 6/ APR-ZX8					
Keypad 7/ APR-ZX8					
Keypad 8/ APR-ZX8					
Keypad 9/ APR-ZX8					
Keypad 10/ APR-ZX8					
Keypad 11/ APR-ZX8					
Keypad 12/ APR-ZX8					
Keypad 13/ APR-ZX8					
Keypad 14/ APR-ZX8					
Keypad 15/ APR-ZX8					

# Wireless System Planning

Serial # Sticker	Description	Path Zone (Entry Point)	Path Zone	Path Zone	Path Zone
MG32LRF 1					
MG32LRF 2					
MG32LRF 3					
MG32LRF 4					

Serial # Sticker	Description
PGM 1	
PGM 2	
PGM 3	
PGM 4	
PGM 5	
PGM 6	
PGM 7	
PGM 8	

Serial # Sticker	Description
PGM 9	
PGM 10	
PGM 11	
PGM 12	
PGM 13	
PGM 14	
PGM 15	
PGM 16	

Serial # Sticker	Description
Repeater 1	

Serial # Sticker	Description
Repeater 2	

Serial # Sticker		Zone Description	Armed when...		Serial # Sticker		Armed when...				
Wireless/APR-ZX8	Zone#		Stay	Sleep	Full	Wireless/APR-ZX8	Zone#	Zone Description	Stay	Sleep	Full
Zone			<input type="checkbox"/>	<input type="checkbox"/>	<input type="checkbox"/>	Zone			<input type="checkbox"/>	<input type="checkbox"/>	<input type="checkbox"/>
Zone			<input type="checkbox"/>	<input type="checkbox"/>	<input type="checkbox"/>	Zone			<input type="checkbox"/>	<input type="checkbox"/>	<input type="checkbox"/>
Zone			<input type="checkbox"/>	<input type="checkbox"/>	<input type="checkbox"/>	Zone			<input type="checkbox"/>	<input type="checkbox"/>	<input type="checkbox"/>
Zone			<input type="checkbox"/>	<input type="checkbox"/>	<input type="checkbox"/>	Zone			<input type="checkbox"/>	<input type="checkbox"/>	<input type="checkbox"/>
Zone			<input type="checkbox"/>	<input type="checkbox"/>	<input type="checkbox"/>	Zone			<input type="checkbox"/>	<input type="checkbox"/>	<input type="checkbox"/>
Zone			<input type="checkbox"/>	<input type="checkbox"/>	<input type="checkbox"/>	Zone			<input type="checkbox"/>	<input type="checkbox"/>	<input type="checkbox"/>
Zone			<input type="checkbox"/>	<input type="checkbox"/>	<input type="checkbox"/>	Zone			<input type="checkbox"/>	<input type="checkbox"/>	<input type="checkbox"/>
Zone			<input type="checkbox"/>	<input type="checkbox"/>	<input type="checkbox"/>	Zone			<input type="checkbox"/>	<input type="checkbox"/>	<input type="checkbox"/>
Zone			<input type="checkbox"/>	<input type="checkbox"/>	<input type="checkbox"/>	Zone			<input type="checkbox"/>	<input type="checkbox"/>	<input type="checkbox"/>
Zone			<input type="checkbox"/>	<input type="checkbox"/>	<input type="checkbox"/>	Zone			<input type="checkbox"/>	<input type="checkbox"/>	<input type="checkbox"/>
Zone			<input type="checkbox"/>	<input type="checkbox"/>	<input type="checkbox"/>	Zone			<input type="checkbox"/>	<input type="checkbox"/>	<input type="checkbox"/>
Zone			<input type="checkbox"/>	<input type="checkbox"/>	<input type="checkbox"/>	Zone			<input type="checkbox"/>	<input type="checkbox"/>	<input type="checkbox"/>
Zone			<input type="checkbox"/>	<input type="checkbox"/>	<input type="checkbox"/>	Zone			<input type="checkbox"/>	<input type="checkbox"/>	<input type="checkbox"/>
Zone			<input type="checkbox"/>	<input type="checkbox"/>	<input type="checkbox"/>	Zone			<input type="checkbox"/>	<input type="checkbox"/>	<input type="checkbox"/>
Zone			<input type="checkbox"/>	<input type="checkbox"/>	<input type="checkbox"/>	Zone			<input type="checkbox"/>	<input type="checkbox"/>	<input type="checkbox"/>
Zone			<input type="checkbox"/>	<input type="checkbox"/>	<input type="checkbox"/>	Zone			<input type="checkbox"/>	<input type="checkbox"/>	<input type="checkbox"/>
Zone			<input type="checkbox"/>	<input type="checkbox"/>	<input type="checkbox"/>	Zone			<input type="checkbox"/>	<input type="checkbox"/>	<input type="checkbox"/>
Zone			<input type="checkbox"/>	<input type="checkbox"/>	<input type="checkbox"/>	Zone			<input type="checkbox"/>	<input type="checkbox"/>	<input type="checkbox"/>
Zone			<input type="checkbox"/>	<input type="checkbox"/>	<input type="checkbox"/>	Zone			<input type="checkbox"/>	<input type="checkbox"/>	<input type="checkbox"/>
Zone			<input type="checkbox"/>	<input type="checkbox"/>	<input type="checkbox"/>	Zone			<input type="checkbox"/>	<input type="checkbox"/>	<input type="checkbox"/>
Zone			<input type="checkbox"/>	<input type="checkbox"/>	<input type="checkbox"/>	Zone			<input type="checkbox"/>	<input type="checkbox"/>	<input type="checkbox"/>
Zone			<input type="checkbox"/>	<input type="checkbox"/>	<input type="checkbox"/>	Zone			<input type="checkbox"/>	<input type="checkbox"/>	<input type="checkbox"/>
Zone			<input type="checkbox"/>	<input type="checkbox"/>	<input type="checkbox"/>	Zone			<input type="checkbox"/>	<input type="checkbox"/>	<input type="checkbox"/>
Zone			<input type="checkbox"/>	<input type="checkbox"/>	<input type="checkbox"/>	Zone			<input type="checkbox"/>	<input type="checkbox"/>	<input type="checkbox"/>
Zone			<input type="checkbox"/>	<input type="checkbox"/>	<input type="checkbox"/>	Zone			<input type="checkbox"/>	<input type="checkbox"/>	<input type="checkbox"/>
Zone			<input type="checkbox"/>	<input type="checkbox"/>	<input type="checkbox"/>	Zone			<input type="checkbox"/>	<input type="checkbox"/>	<input type="checkbox"/>
Zone			<input type="checkbox"/>	<input type="checkbox"/>	<input type="checkbox"/>	Zone			<input type="checkbox"/>	<input type="checkbox"/>	<input type="checkbox"/>
Zone			<input type="checkbox"/>	<input type="checkbox"/>	<input type="checkbox"/>	Zone			<input type="checkbox"/>	<input type="checkbox"/>	<input type="checkbox"/>
Zone			<input type="checkbox"/>	<input type="checkbox"/>	<input type="checkbox"/>	Zone			<input type="checkbox"/>	<input type="checkbox"/>	<input type="checkbox"/>
Zone			<input type="checkbox"/>	<input type="checkbox"/>	<input type="checkbox"/>	Zone			<input type="checkbox"/>	<input type="checkbox"/>	<input type="checkbox"/>
Zone			<input type="checkbox"/>	<input type="checkbox"/>	<input type="checkbox"/>	Zone			<input type="checkbox"/>	<input type="checkbox"/>	<input type="checkbox"/>
Zone			<input type="checkbox"/>	<input type="checkbox"/>	<input type="checkbox"/>	Zone			<input type="checkbox"/>	<input type="checkbox"/>	<input type="checkbox"/>
Zone			<input type="checkbox"/>	<input type="checkbox"/>	<input type="checkbox"/>	Zone			<input type="checkbox"/>	<input type="checkbox"/>	<input type="checkbox"/>
Zone			<input type="checkbox"/>	<input type="checkbox"/>	<input type="checkbox"/>	Zone			<input type="checkbox"/>	<input type="checkbox"/>	<input type="checkbox"/>
Zone			<input type="checkbox"/>	<input type="checkbox"/>	<input type="checkbox"/>	Zone			<input type="checkbox"/>	<input type="checkbox"/>	<input type="checkbox"/>
Zone			<input type="checkbox"/>	<input type="checkbox"/>	<input type="checkbox"/>	Zone			<input type="checkbox"/>	<input type="checkbox"/>	<input type="checkbox"/>
Zone			<input type="checkbox"/>	<input type="checkbox"/>	<input type="checkbox"/>	Zone			<input type="checkbox"/>	<input type="checkbox"/>	<input type="checkbox"/>
Zone			<input type="checkbox"/>	<input type="checkbox"/>	<input type="checkbox"/>	Zone			<input type="checkbox"/>	<input type="checkbox"/>	<input type="checkbox"/>
Zone			<input type="checkbox"/>	<input type="checkbox"/>	<input type="checkbox"/>	Zone			<input type="checkbox"/>	<input type="checkbox"/>	<input type="checkbox"/>
Zone			<input type="checkbox"/>	<input type="checkbox"/>	<input type="checkbox"/>	Zone			<input type="checkbox"/>	<input type="checkbox"/>	<input type="checkbox"/>
Zone			<input type="checkbox"/>	<input type="checkbox"/>	<input type="checkbox"/>	Zone			<input type="checkbox"/>	<input type="checkbox"/>	<input type="checkbox"/>
Zone			<input type="checkbox"/>	<input type="checkbox"/>	<input type="checkbox"/>	Zone			<input type="checkbox"/>	<input type="checkbox"/>	<input type="checkbox"/>
Zone			<input type="checkbox"/>	<input type="checkbox"/>	<input type="checkbox"/>	Zone			<input type="checkbox"/>	<input type="checkbox"/>	<input type="checkbox"/>
Zone			<input type="checkbox"/>	<input type="checkbox"/>	<input type="checkbox"/>	Zone			<input type="checkbox"/>	<input type="checkbox"/>	<input type="checkbox"/>
Zone			<input type="checkbox"/>	<input type="checkbox"/>	<input type="checkbox"/>	Zone			<input type="checkbox"/>	<input type="checkbox"/>	<input type="checkbox"/>
Zone			<input type="checkbox"/>	<input type="checkbox"/>	<input type="checkbox"/>	Zone			<input type="checkbox"/>	<input type="checkbox"/>	<input type="checkbox"/>
Zone			<input type="checkbox"/>	<input type="checkbox"/>	<input type="checkbox"/>	Zone			<input type="checkbox"/>	<input type="checkbox"/>	<input type="checkbox"/>
Zone			<input type="checkbox"/>	<input type="checkbox"/>	<input type="checkbox"/>	Zone			<input type="checkbox"/>	<input type="checkbox"/>	<input type="checkbox"/>
Zone			<input type="checkbox"/>	<input type="checkbox"/>	<input type="checkbox"/>	Zone			<input type="checkbox"/>	<input type="checkbox"/>	<input type="checkbox"/>
Zone			<input type="checkbox"/>	<input type="checkbox"/>	<input type="checkbox"/>	Zone			<input type="checkbox"/>	<input type="checkbox"/>	<input type="checkbox"/>
Zone			<input type="checkbox"/>	<input type="checkbox"/>	<input type="checkbox"/>	Zone			<input type="checkbox"/>	<input type="checkbox"/>	<input type="checkbox"/>
Zone			<input type="checkbox"/>	<input type="checkbox"/>	<input type="checkbox"/>	Zone			<input type="checkbox"/>	<input type="checkbox"/>	<input type="checkbox"/>
Zone			<input type="checkbox"/>	<input type="checkbox"/>	<input type="checkbox"/>	Zone			<input type="checkbox"/>	<input type="checkbox"/>	<input type="checkbox"/>
Zone			<input type="checkbox"/>	<input type="checkbox"/>	<input type="checkbox"/>	Zone			<input type="checkbox"/>	<input type="checkbox"/>	<input type="checkbox"/>
Zone			<input type="checkbox"/>	<input type="checkbox"/>	<input type="checkbox"/>	Zone			<input type="checkbox"/>	<input type="checkbox"/>	<input type="checkbox"/>
Zone			<input type="checkbox"/>	<input type="checkbox"/>	<input type="checkbox"/>	Zone			<input type="checkbox"/>	<input type="checkbox"/>	<input type="checkbox"/>
Zone			<input type="checkbox"/>	<input type="checkbox"/>	<input type="checkbox"/>	Zone			<input type="checkbox"/>	<input type="checkbox"/>	<input type="checkbox"/>
Zone			<input type="checkbox"/>	<input type="checkbox"/>	<input type="checkbox"/>	Zone			<input type="checkbox"/>	<input type="checkbox"/>	<input type="checkbox"/>
Zone			<input type="checkbox"/>	<input type="checkbox"/>	<input type="checkbox"/>	Zone			<input type="checkbox"/>	<input type="checkbox"/>	<input type="checkbox"/>
Zone			<input type="checkbox"/>	<input type="checkbox"/>	<input type="checkbox"/>	Zone			<input type="checkbox"/>	<input type="checkbox"/>	<input type="checkbox"/>
Zone			<input type="checkbox"/>	<input type="checkbox"/>	<input type="checkbox"/>	Zone			<input type="checkbox"/>	<input type="checkbox"/>	<input type="checkbox"/>
Zone			<input type="checkbox"/>	<input type="checkbox"/>	<input type="checkbox"/>	Zone			<input type="checkbox"/>	<input type="checkbox"/>	<input type="checkbox"/>
Zone			<input type="checkbox"/>	<input type="checkbox"/>	<input type="checkbox"/>	Zone			<input type="checkbox"/>	<input type="checkbox"/>	<input type="checkbox"/>
Zone			<input type="checkbox"/>	<input type="checkbox"/>	<input type="checkbox"/>	Zone			<input type="checkbox"/>	<input type="checkbox"/>	<input type="checkbox"/>
Zone			<input type="checkbox"/>	<input type="checkbox"/>	<input type="checkbox"/>	Zone			<input type="checkbox"/>	<input type="checkbox"/>	<input type="checkbox"/>
Zone			<input type="checkbox"/>	<input type="checkbox"/>	<input type="checkbox"/>	Zone			<input type="checkbox"/>	<input type="checkbox"/>	<input type="checkbox"/>
Zone			<input type="checkbox"/>	<input type="checkbox"/>	<input type="checkbox"/>	Zone			<input type="checkbox"/>	<input type="checkbox"/>	<input type="checkbox"/>
Zone			<input type="checkbox"/>	<input type="checkbox"/>	<input type="checkbox"/>	Zone			<input type="checkbox"/>	<input type="checkbox"/>	<input type="checkbox"/>
Zone			<input type="checkbox"/>	<input type="checkbox"/>	<input type="checkbox"/>	Zone			<input type="checkbox"/>	<input type="checkbox"/>	<input type="checkbox"/>
Zone			<input type="checkbox"/>	<input type="checkbox"/>	<input type="checkbox"/>	Zone			<input type="checkbox"/>	<input type="checkbox"/>	<input type="checkbox"/>
Zone			<input type="checkbox"/>	<input type="checkbox"/>	<input type="checkbox"/>	Zone			<input type="checkbox"/>	<input type="checkbox"/>	<input type="checkbox"/>
Zone			<input type="checkbox"/>	<input type="checkbox"/>	<input type="checkbox"/>	Zone			<input type="checkbox"/>	<input type="checkbox"/>	<input type="checkbox"/>
Zone			<input type="checkbox"/>	<input type="checkbox"/>	<input type="checkbox"/>	Zone			<input type="checkbox"/>	<input type="checkbox"/>	<input type="checkbox"/>
Zone			<input type="checkbox"/>	<input type="checkbox"/>	<input type="checkbox"/>	Zone			<input type="checkbox"/>	<input type="checkbox"/>	<input type="checkbox"/>
Zone			<input type="checkbox"/>	<input type="checkbox"/>	<input type="checkbox"/>	Zone			<input type="checkbox"/>	<input type="checkbox"/>	<input type="checkbox"/>
Zone			<input type="checkbox"/>	<input type="checkbox"/>	<input type="checkbox"/>	Zone			<input type="checkbox"/>	<input type="checkbox"/>	<input type="checkbox"/>
Zone			<input type="checkbox"/>	<input type="checkbox"/>	<input type="checkbox"/>	Zone			<input type="checkbox"/>	<input type="checkbox"/>	<input type="checkbox"/>
Zone			<input type="checkbox"/>	<input type="checkbox"/>	<input type="checkbox"/>	Zone			<input type="checkbox"/>	<input type="checkbox"/>	<input type="checkbox"/>
Zone			<input type="checkbox"/>	<input type="checkbox"/>	<input type="checkbox"/>	Zone			<input type="checkbox"/>	<input type="checkbox"/>	<input type="checkbox"/>
Zone			<input type="checkbox"/>	<input type="checkbox"/>	<input type="checkbox"/>	Zone			<input type="checkbox"/>	<input type="checkbox"/>	<input type="checkbox"/>
Zone			<input type="checkbox"/>	<input type="checkbox"/>	<input type="checkbox"/>	Zone			<input type="checkbox"/>	<input type="checkbox"/>	<input type="checkbox"/>
Zone			<input type="checkbox"/>	<input type="checkbox"/>	<input type="checkbox"/>	Zone			<input type="checkbox"/>	<input type="checkbox"/>	<input type="checkbox"/>
Zone			<input type="checkbox"/>	<input type="checkbox"/>	<input type="checkbox"/>	Zone			<input type="checkbox"/>	<input type="checkbox"/>	<input type="checkbox"/>
Zone			<input type="checkbox"/>	<input type="checkbox"/>	<input type="checkbox"/>	Zone			<input type="checkbox"/>	<input type="checkbox"/>	<input type="checkbox"/>
Zone			<input type="checkbox"/>	<input type="checkbox"/>	<input type="checkbox"/>	Zone			<input type="checkbox"/>	<input type="checkbox"/>	<input type="checkbox"/>
Zone			<input type="checkbox"/>	<input type="checkbox"/>	<input type="checkbox"/>	Zone			<input type="checkbox"/>	<input type="checkbox"/>	<input type="checkbox"/>
Zone			<input type="checkbox"/>	<input type="checkbox"/>	<input type="checkbox"/>	Zone			<input type="checkbox"/>	<input type="checkbox"/>	<input type="checkbox"/>
Zone			<input type="checkbox"/>	<input type="checkbox"/>	<input type="checkbox"/>	Zone			<input type="checkbox"/>	<input type="checkbox"/>	<input type="checkbox"/>
Zone			<input type="checkbox"/>	<input type="checkbox"/>	<input type="checkbox"/>	Zone			<input type="checkbox"/>	<input type="checkbox"/>	<input type="checkbox"/>
Zone			<input type="checkbox"/>	<input type="checkbox"/>	<input type="checkbox"/>	Zone			<input type="checkbox"/>	<input type="checkbox"/>	<input type="checkbox"/>
Zone			<input type="checkbox"/>	<input type="checkbox"/>	<input type="checkbox"/>	Zone			<input type="checkbox"/>	<input type="checkbox"/>	<input type="checkbox"/>
Zone			<input type="checkbox"/>	<input type="checkbox"/>	<input type="checkbox"/>	Zone			<input type="checkbox"/>	<input type="checkbox"/>	<input type="checkbox"/>
Zone			<input type="checkbox"/>	<input type="checkbox"/>	<input type="checkbox"/>	Zone			<input type="checkbox"/>	<input type="checkbox"/>	<input type="checkbox"/>
Zone			<input type="checkbox"/>	<input type="checkbox"/>	<input type="checkbox"/>	Zone			<input type="checkbox"/>	<input type="checkbox"/>	<input type="checkbox"/>
Zone			<input type="checkbox"/>	<input type="checkbox"/>	<input type="checkbox"/>	Zone			<input type="checkbox"/>	<input type="checkbox"/>	<input type="checkbox"/>
Zone			<input type="checkbox"/>	<input type="checkbox"/>	<input type="checkbox"/>	Zone			<input type="checkbox"/>	<input type="checkbox"/>	<input type="checkbox"/>
Zone			<input type="checkbox"/>	<input type="checkbox"/>	<input type="checkbox"/>	Zone			<input type="checkbox"/>	<input type="checkbox"/>	<input type="checkbox"/>
Zone			<input type="checkbox"/>	<input type="checkbox"/>	<input type="checkbox"/>	Zone			<input type="checkbox"/>	<input type="checkbox"/>	<input type="checkbox"/>
Zone			<input type="checkbox"/>	<input type="checkbox"/>	<input type="checkbox"/>	Zone			<input type="checkbox"/>	<input type="checkbox"/>	<input type="checkbox"/>
Zone			<input type="checkbox"/>	<input type="checkbox"/>	<input type="checkbox"/>	Zone			<input type="checkbox"/>	<input type="checkbox"/>	<input type="checkbox"/>
Zone			<input type="checkbox"/>	<input type="checkbox"/>	<input type="checkbox"/>	Zone			<input type="checkbox"/>	<input type="checkbox"/>	<input type="checkbox"/>
Zone			<input type="checkbox"/>	<input type="checkbox"/>	<input type="checkbox"/>	Zone			<input type="checkbox"/>	<input type="checkbox"/>	<input type="checkbox"/>
Zone			<input type="checkbox"/>	<input type="checkbox"/>	<input type="checkbox"/>	Zone			<input type="checkbox"/>	<input type="checkbox"/>	<input type="checkbox"/>
Zone			<input type="checkbox"/>	<input type="checkbox"/>	<input type="checkbox"/>	Zone			<input type="checkbox"/>	<input type="checkbox"/>	<input type="checkbox"/>
Zone			<input type="checkbox"/>	<input type="checkbox"/>	<input type="checkbox"/>	Zone			<input type="checkbox"/>	<input type="checkbox"/>	<input type="checkbox"/>
Zone			<input type="checkbox"/>	<input type="checkbox"/>	<input type="checkbox"/>	Zone			<input type="checkbox"/>	<input type="checkbox"/>	<input type="checkbox"/>
Zone			<input type="checkbox"/>	<input type="checkbox"/>	<input type="checkbox"/>	Zone			<input type="checkbox"/>	<input type="checkbox"/>	<input type="checkbox"/>
Zone			<input type="checkbox"/>	<input type="checkbox"/>	<input type="checkbox"/>	Zone			<input type="checkbox"/>	<input type="checkbox"/>	<input type="checkbox"/>
Zone			<input type="checkbox"/>	<input type="checkbox"/>	<input type="checkbox"/>	Zone			<input type="checkbox"/>	<input type="checkbox"/>	<input type="checkbox"/>
Zone			<input type="checkbox"/>	<input type="checkbox"/>	<input type="checkbox"/>	Zone			<input type="checkbox"/>	<input type="checkbox"/>	<input type="checkbox"/>
Zone			<input type="checkbox"/>	<input type="checkbox"/>	<input type="checkbox"/>	Zone			<input type="checkbox"/>	<input type="checkbox"/>	<input type="checkbox"/>
Zone			<input type="checkbox"/>	<input type="checkbox"/>	<input type="checkbox"/>	Zone			<input type="checkbox"/>	<input type="checkbox"/>	<input type="checkbox"/>
Zone			<input type="checkbox"/>	<input type="checkbox"/>	<input type="checkbox"/>	Zone			<input type="checkbox"/>	<input type="checkbox"/>	<input type="checkbox"/>
Zone			<input type="checkbox"/>	<input type="checkbox"/>	<input type="checkbox"/>	Zone			<input type="checkbox"/>	<input type="checkbox"/>	<input type="checkbox"/>
Zone			<input type="checkbox"/>	<input type="checkbox"/>	<input type="checkbox"/>	Zone			<input type="checkbox"/>	<input type="checkbox"/>	<input type="checkbox"/>
Zone			<input type="checkbox"/>	<input type="checkbox"/>	<input type="checkbox"/>	Zone			<input type="checkbox"/>	<input type="checkbox"/>	<input type="checkbox"/>
Zone			<input type="checkbox"/>	<input type="checkbox"/>	<input type="checkbox"/>	Zone			<input type="checkbox"/>	<input type="checkbox"/>	<input type="checkbox"/>
Zone			<input type="checkbox"/>	<input type="checkbox"/>	<input type="checkbox"/>	Zone			<input type="checkbox"/>	<input type="checkbox"/>	<input type="checkbox"/>
Zone			<input type="checkbox"/>	<input type="checkbox"/>	<input type="checkbox"/>	Zone			<input type="checkbox"/>	<input type="checkbox"/>	<input type="checkbox"/>
Zone			<input type="checkbox"/>	<input type="checkbox"/>	<input type="checkbox"/>	Zone			<input type="checkbox"/>	<input type="checkbox"/>	<input type="checkbox"/>
Zone			<input type="checkbox"/>	<input type="checkbox"/>	<input type="checkbox"/>	Zone			<input type="checkbox"/>	<input type="checkbox"/>	<input type="checkbox"/>
Zone			<input type="checkbox"/>	<input type="checkbox"/>	<input type="checkbox"/>	Zone			<input type="checkbox"/>	<input type="checkbox"/>	<input type="checkbox"/>
Zone			<input type="checkbox"/>	<input type="checkbox"/>	<input type="checkbox"/>	Zone			<input type="checkbox"/>	<input type="checkbox"/>	<input type="checkbox"/>
Zone			<input type="checkbox"/>	<input type="checkbox"/>	<input type="checkbox"/>	Zone			<input type="checkbox"/>	<input type="checkbox"/>	<input type="checkbox"/>
Zone			<input type="checkbox"/>	<input type="checkbox"/>	<input type="checkbox"/>	Zone			<input type="checkbox"/>	<input type="checkbox"/>	<input type="checkbox"/>
Zone			<input type="checkbox"/>	<input type="checkbox"/>	<input type="checkbox"/>	Zone			<input type="checkbox"/>	<input type="checkbox"/>	<input type="checkbox"/>
Zone			<input type="checkbox"/>	<input type="checkbox"/>	<input type="checkbox"/>	Zone			<input type="checkbox"/>	<input type="checkbox"/>	<input type="checkbox"/>
Zone			<input type="checkbox"/>	<input type="checkbox"/>	<input type="checkbox"/>	Zone			<input type="checkbox"/>	<input type="checkbox"/>	<input type="checkbox"/>
Zone			<input type="checkbox"/>	<input type="checkbox"/>	<input type="checkbox"/>	Zone			<input type="checkbox"/>	<input type="checkbox"/>	<input type="checkbox"/>
Zone			<input type="checkbox"/>	<input type="checkbox"/>	<input type="checkbox"/>	Zone			<input type="checkbox"/>	<input type="checkbox"/>	<input type="checkbox"/>
Zone			<input type="checkbox"/>	<input type="checkbox"/>	<input type="checkbox"/>	Zone			<input type="checkbox"/>	<input type="checkbox"/>	<input type="checkbox"/>
Zone			<input type="checkbox"/>	<input type="checkbox"/>	<input type="checkbox"/>	Zone			<input type="checkbox"/>	<input type="checkbox"/>	<input type="checkbox"/>
Zone			<input type="checkbox"/>	<input type="checkbox"/>	<input type="checkbox"/>	Zone			<input type="checkbox"/>	<input type="checkbox"/>	<input type="checkbox"/>
Zone			<input type="checkbox"/>	<input type="checkbox"/>	<input type="checkbox"/>	Zone			<input type="checkbox"/>	<input type="checkbox"/>	<input type="checkbox"/>
Zone			<input type="checkbox"/>	<input type="checkbox"/>	<input type="checkbox"/>	Zone			<input type="checkbox"/>	<input type="checkbox"/>	<input type="checkbox"/>
Zone			<input type="checkbox"/>	<input type="checkbox"/>	<input type="checkbox"/>	Zone			<input type="checkbox"/>	<input type="checkbox"/>	<input type="checkbox"/>
Zone			<input type="checkbox"/>	<input type="checkbox"/>	<input type="checkbox"/>	Zone			<input type="checkbox"/>	<input type="checkbox"/>	<input type="checkbox"/>
Zone			<input type="checkbox"/>	<input type="checkbox"/>	<input type="checkbox"/>	Zone			<input type="checkbox"/>	<input type="checkbox"/>	<input type="checkbox"/>
Zone			<input type="checkbox"/>	<input type="checkbox"/>	<input type="checkbox"/>	Zone			<input type="checkbox"/>	<input type="checkbox"/>	<input type="checkbox"/>
Zone			<input type="checkbox"/>	<input type="checkbox"/>	<input type="checkbox"/>	Zone			<input type="checkbox"/>	<input type="checkbox"/>	



# Zone Programming

Zone Definitions	Stay Arm	Sleep Arm	Fully Arm
<b>01</b> = Entry Delay 1	Entry Delay 1	Entry Delay 1	Entry Delay 1
<b>02</b> = Entry Delay 2	Entry Delay 2	Entry Delay 2	Entry Delay 2
<b>03</b> = Entry Delay 1 (Full Arm)	Not Armed	Not Armed	Entry Delay 1
<b>04</b> = Entry Delay2 (Full Arm)	Not Armed	Not Armed	Entry Delay 2
<b>05</b> = Follow	Follow*	Follow*	Follow
<b>06</b> = Follow (Sleep/Full Arm)	Not Armed	Follow*	Follow
<b>07</b> = Follow (Full Arm)	Not Armed	Not Armed	Follow
<b>08</b> = Instant	Instant*	Instant*	Instant
<b>09</b> = Instant (Sleep/Full Arm)	Not Armed	Instant*	Instant
<b>10</b> = Instant (Full Arm)	Not Armed	Not Armed	Instant
<b>11</b> = Instant Fire			
<b>12</b> = Delayed Fire			

Zone Definitions
<b>13</b> = Instant Fire Silent
<b>14</b> = Delayed Fire Silent
<b>15</b> = 24Hr. Buzzer
<b>16</b> = 24Hr. Burglary
<b>17</b> = 24Hr. Hold-up
<b>18</b> = 24Hr. Gas
<b>19</b> = 24Hr. Heat
<b>20</b> = 24Hr. Water
<b>21</b> = 24Hr. Freeze
<b>22</b> = Outdoor motion - SP Series
<b>23</b> = Doorbell - SP Series

Partition Assignment
[1]- Partition 1
[2]- Partition 2
[3]- Both partitions

Zone Options
[1] = Auto-zone Shutdown
[2] = Bypassable Zone
[3] = RF Supervision
[4] [5]
OFF OFF Audible Alarm
OFF ON Pulsed Alarm
ON OFF Silent Alarm
ON ON Report Only
[6] = Intellizone
[7] = Delay alarm transmission
[8] = Force Zone

\* Flex-Instant = Zone will follow the delay at section [720], (default is 15 seconds / 0 = instant zone)

Zone*	Section	Zone Definition	Partition	Zone Options	Section	Wireless SN or press tamper/learn To delete, enter 000000
Zone 1: _____	[001]	___/___	___	1 2 3 4 5 6 7 8	[061]	___/___/___/___/___
Zone 2: _____	[002]	___/___	___	1 2 3 4 5 6 7 8	[062]	___/___/___/___/___
Zone 3: _____	[003]	___/___	___	1 2 3 4 5 6 7 8	[063]	___/___/___/___/___
Zone 4: _____	[004]	___/___	___	1 2 3 4 5 6 7 8	[064]	___/___/___/___/___
Zone 5: _____	[005]	___/___	___	1 2 3 4 5 6 7 8	[065]	___/___/___/___/___
Zone 6: _____	[006]	___/___	___	1 2 3 4 5 6 7 8	[066]	___/___/___/___/___
Zone 7: _____	[007]	___/___	___	1 2 3 4 5 6 7 8	[067]	___/___/___/___/___
Zone 8: _____	[008]	___/___	___	1 2 3 4 5 6 7 8	[068]	___/___/___/___/___
Zone 9: _____	[009]	___/___	___	1 2 3 4 5 6 7 8	[069]	___/___/___/___/___
Zone 10: _____	[010]	___/___	___	1 2 3 4 5 6 7 8	[070]	___/___/___/___/___
Zone 11: _____	[011]	___/___	___	1 2 3 4 5 6 7 8	[071]	___/___/___/___/___
Zone 12: _____	[012]	___/___	___	1 2 3 4 5 6 7 8	[072]	___/___/___/___/___
Zone 13: _____	[013]	___/___	___	1 2 3 4 5 6 7 8	[073]	___/___/___/___/___
Zone 14: _____	[014]	___/___	___	1 2 3 4 5 6 7 8	[074]	___/___/___/___/___
Zone 15: _____	[015]	___/___	___	1 2 3 4 5 6 7 8	[075]	___/___/___/___/___
Zone 16: _____	[016]	___/___	___	1 2 3 4 5 6 7 8	[076]	___/___/___/___/___
Zone 17: _____	[017]	___/___	___	1 2 3 4 5 6 7 8	[077]	___/___/___/___/___
Zone 18: _____	[018]	___/___	___	1 2 3 4 5 6 7 8	[078]	___/___/___/___/___
Zone 19: _____	[019]	___/___	___	1 2 3 4 5 6 7 8	[079]	___/___/___/___/___
Zone 20: _____	[020]	___/___	___	1 2 3 4 5 6 7 8	[080]	___/___/___/___/___
Zone 21: _____	[021]	___/___	___	1 2 3 4 5 6 7 8	[081]	___/___/___/___/___
Zone 22: _____	[022]	___/___	___	1 2 3 4 5 6 7 8	[082]	___/___/___/___/___
Zone 23: _____	[023]	___/___	___	1 2 3 4 5 6 7 8	[083]	___/___/___/___/___
Zone 24: _____	[024]	___/___	___	1 2 3 4 5 6 7 8	[084]	___/___/___/___/___
Zone 25: _____	[025]	___/___	___	1 2 3 4 5 6 7 8	[085]	___/___/___/___/___
Zone 26: _____	[026]	___/___	___	1 2 3 4 5 6 7 8	[086]	___/___/___/___/___
Zone 27: _____	[027]	___/___	___	1 2 3 4 5 6 7 8	[087]	___/___/___/___/___
Zone 28: _____	[028]	___/___	___	1 2 3 4 5 6 7 8	[088]	___/___/___/___/___
Zone 29: _____	[029]	___/___	___	1 2 3 4 5 6 7 8	[089]	___/___/___/___/___
Zone 30: _____	[030]	___/___	___	1 2 3 4 5 6 7 8	[090]	___/___/___/___/___
Zone 31: _____	[031]	___/___	___	1 2 3 4 5 6 7 8	[091]	___/___/___/___/___
Zone 32: _____	[032]	___/___	___	1 2 3 4 5 6 7 8	[092]	___/___/___/___/___

\* See Zone Recognition table on next page.

## Zone Recognition (MG Series)

	<b>MG5000</b> No ATZ	<b>MG5000</b> ATZ	<b>MG5050</b> No ATZ	<b>MG5050</b> ATZ
Zone 1:	Panel Input 1	Panel Input 1A	Panel Input 1	Panel Input 1A
Zone 2:	Panel Input 2	Panel Input 2A	Panel Input 2	Panel Input 2A
Zone 3:	<b>ZX8 A Input 1</b>	ZX8 A Input 1B	Panel Input 3	Panel Input 3A
Zone 4:	Input 2	ZX8 A Input 2B	Panel Input 4	Panel Input 4A
Zone 5:	Input 3	<b>ZX8 A Input 1</b>	Panel Input 5	Panel Input 5A
Zone 6:	Input 4	Input 2	<b>ZX8 A Input 1</b>	Panel Input 1B
Zone 7:	Input 5	Input 3	Input 2	Panel Input 2B
Zone 8:	Input 6	Input 4	Input 3	Panel Input 3B
Zone 9:	Input 7	Input 5	Input 4	Panel Input 4B
Zone 10:	Input 8	Input 6	Input 5	Panel Input 5B
Zone 11:	<b>ZX8 B Input 1</b>	Input 7	Input 6	<b>ZX8 A Input 1</b>
Zone 12:	Input 2	Input 8	Input 7	Input 2
Zone 13:	Input 3	<b>ZX8 B Input 1</b>	Input 8	Input 3
Zone 14:	Input 4	Input 2	<b>ZX8 B Input 1</b>	Input 4
Zone 15:	Input 5	Input 3	Input 2	Input 5
Zone 16:	Input 6	Input 4	Input 3	Input 6
Zone 17:	Input 7	Input 5	Input 4	Input 7
Zone 18:	Input 8	Input 6	Input 5	Input 8
Zone 19:	<b>ZX8 C Input 1</b>	Input 7	Input 6	<b>ZX8 B Input 1</b>
Zone 20:	Input 2	Input 8	Input 7	Input 2
Zone 21:	Input 3	<b>ZX8 C Input 1</b>	Input 8	Input 3
Zone 22:	Input 4	Input 2	<b>ZX8 C Input 1</b>	Input 4
Zone 23:	Input 5	Input 3	Input 2	Input 5
Zone 24:	Input 6	Input 4	Input 3	Input 6
Zone 25:	Input 7	Input 5	Input 4	Input 7
Zone 26:	Input 8	Input 6	Input 5	Input 8
Zone 27:	N/A	Input 7	Input 6	<b>ZX8 C Input 1</b>
Zone 28:	N/A	Input 8	Input 7	Input 2
Zone 29:	N/A	N/A	Input 8	Input 3
Zone 30:	N/A	N/A	N/A	Input 4
Zone 31:	N/A	N/A	N/A	Input 5
Zone 32:	N/A	N/A	N/A	Input 6



Jumper settings for the APR-ZX8: **A** = Panel +1, **B** = Panel + 9, **C** = Panel + 17.



If a zone is already programmed and you assign a device to the same zone, a wireless zone will overwrite a keypad/hardwire zone, and a keypad zone will overwrite a hardwire zone.

## Zone Recognition (SP Series)

	<b>SP5500 No ATZ</b>	<b>SP5500 ATZ</b>	<b>SP6000 No ATZ</b>	<b>SP6000 ATZ</b>	<b>SP7000 No ATZ</b>	<b>SP7000 ATZ</b>
Zone 1:	Panel Input 1	Panel Input 1A	Panel Input 1	Panel Input 1A	Panel Input 1	Panel Input 1A
Zone 2:	Panel Input 2	Panel Input 2A	Panel Input 2	Panel Input 2A	Panel Input 2	Panel Input 2A
Zone 3:	Panel Input 3	Panel Input 3A	Panel Input 3	Panel Input 3A	Panel Input 3	Panel Input 3A
Zone 4:	Panel Input 4	Panel Input 4A	Panel Input 4	Panel Input 4A	Panel Input 4	Panel Input 4A
Zone 5:	Panel Input 5	Panel Input 5A	Panel Input 5	Panel Input 5A	Panel Input 5	Panel Input 5A
Zone 6:	<b>ZX8 A Input 1</b>	Panel Input 1B	Panel Input 6	Panel Input 6A	Panel Input 6	Panel Input 6A
Zone 7:	Input 2	Panel Input 2B	Panel Input 7	Panel Input 7A	Panel Input 7	Panel Input 7A
Zone 8:	Input 3	Panel Input 3B	Panel Input 8	Panel Input 8A	Panel Input 8	Panel Input 8A
Zone 9:	Input 4	Panel Input 4B	<b>ZX8 A Input 1</b>	Panel Input 1B	Panel Input 9	Panel Input 9A
Zone 10:	Input 5	Panel Input 5B	Input 2	Panel Input 2B	Panel Input 10	Panel Input 10A
Zone 11:	Input 6	<b>ZX8 A Input 1</b>	Input 3	Panel Input 3B	Panel Input 11	Panel Input 11A
Zone 12:	Input 7	Input 2	Input 4	Panel Input 4B	Panel Input 12	Panel Input 12A
Zone 13:	Input 8	Input 3	Input 5	Panel Input 5B	Panel Input 13	Panel Input 13A
Zone 14:	<b>ZX8 B Input 1</b>	Input 4	Input 6	Panel Input 6B	Panel Input 14	Panel Input 14A
Zone 15:	Input 2	Input 5	Input 7	Panel Input 7B	Panel Input 15	Panel Input 15A
Zone 16:	Input 3	Input 6	Input 8	Panel Input 8B	Panel Input 16	Panel Input 16A
Zone 17:	Input 4	Input 7	<b>ZX8 B Input 1</b>	<b>ZX8 A Input 1</b>	<b>ZX8 A Input 1</b>	Panel Input 1B
Zone 18:	Input 5	Input 8	Input 2	Input 2	Input 2	Panel Input 2B
Zone 19:	Input 6	<b>ZX8 B Input 1</b>	Input 3	Input 3	Input 3	Panel Input 3B
Zone 20:	Input 7	Input 2	Input 4	Input 4	Input 4	Panel Input 4B
Zone 21:	Input 8	Input 3	Input 5	Input 5	Input 5	Panel Input 5B
Zone 22:	<b>ZX8 C Input 1</b>	Input 4	Input 6	Input 6	Input 6	Panel Input 6B
Zone 23:	Input 2	Input 5	Input 7	Input 7	Input 7	Panel Input 7B
Zone 24:	Input 3	Input 6	Input 8	Input 8	Input 8	Panel Input 8B
Zone 25:	Input 4	Input 7	<b>ZX8 C Input 1</b>	<b>ZX8 B Input 1</b>	<b>ZX8 B Input 1</b>	Panel Input 9B
Zone 26:	Input 5	Input 8	Input 2	Input 2	Input 2	Panel Input 10B
Zone 27:	Input 6	<b>ZX8 C Input 1</b>	Input 3	Input 3	Input 3	Panel Input 11B
Zone 28:	Input 7	Input 2	Input 4	Input 4	Input 4	Panel Input 12B
Zone 29:	Input 8	Input 3	Input 5	Input 5	Input 5	Panel Input 13B
Zone 30:	N/A	Input 4	Input 6	Input 6	Input 6	Panel Input 14B
Zone 31:	N/A	Input 5	Input 7	Input 7	Input 7	Panel Input 15B
Zone 32:	N/A	Input 6	Input 8	Input 8	Input 8	Panel Input 16B



Jumper settings for the APR-ZX8: **A** = Panel +1, **B** = Panel + 9, **C** = Panel + 17.



If a zone is already programmed and you assign a device to the same zone, a wireless zone will overwrite a keypad/hardwire zone, and a keypad zone will overwrite a hardwire zone.

## Zone Timers (MG Series)

Section	MG5000	MG5050	Data	Description (Default 060)
[041] Zone 1	(Z1):	(Z1):	___/___/___ (000 to 255) x 10ms	Hardwire Zone 1 Speed
[042] Zone 2	(Z2):	(Z2):	___/___/___ (000 to 255) x 10ms	Hardwire Zone 2 Speed
[043] Zone 3	(Z1 with ATZ):	(Z3):	___/___/___ (000 to 255) x 10ms	Hardwire Zone 3 Speed
[044] Zone 4	(Z2 with ATZ):	(Z4):	___/___/___ (000 to 255) x 10ms	Hardwire Zone 4 Speed
[045] Zone 5		(Z5):	___/___/___ (000 to 255) x 10ms	Hardwire Zone 5 Speed
[046] Zone 6		(Z1 with ATZ):	___/___/___ (000 to 255) x 10ms	Hardwire Zone 6 Speed
[047] Zone 7		(Z2 with ATZ):	___/___/___ (000 to 255) x 10ms	Hardwire Zone 7 Speed
[048] Zone 8		(Z3 with ATZ):	___/___/___ (000 to 255) x 10ms	Hardwire Zone 8 Speed
[049] Zone 9		(Z4 with ATZ):	___/___/___ (000 to 255) x 10ms	Hardwire Zone 9 Speed
[050] Zone 10		(Z5 with ATZ):	___/___/___ (000 to 255) x 10ms	Hardwire Zone 11 Speed
[051] Zone 11			___/___/___ (000 to 255) x 10ms	Hardwire Zone 12 Speed
[052] Zone 12			___/___/___ (000 to 255) x 10ms	Hardwire Zone 13 Speed
[053] Zone 13			___/___/___ (000 to 255) x 10ms	Hardwire Zone 14 Speed
[054] Zone 14			___/___/___ (000 to 255) x 10ms	Hardwire Zone 15 Speed
[055] Zone 15			___/___/___ (000 to 255) x 10ms	Hardwire Zone 16 Speed
[056] Zone 16			___/___/___ (000 to 255) x 10ms	Hardwire Zone 17 Speed

## Zone Timers (SP Series)

Section	SP5500	SP6000	SP7000	Data	Description (Default 060)
[041] Zone 1	(Z1):	(Z1):	(Z1):	___/___/___ (000 to 255) x 10ms	Hardwire Zone 1 Speed
[042] Zone 2	(Z2):	(Z2):	(Z2):	___/___/___ (000 to 255) x 10ms	Hardwire Zone 2 Speed
[043] Zone 3	(Z3):	(Z3):	(Z3):	___/___/___ (000 to 255) x 10ms	Hardwire Zone 3 Speed
[044] Zone 4	(Z4):	(Z4):	(Z4):	___/___/___ (000 to 255) x 10ms	Hardwire Zone 4 Speed
[045] Zone 5	(Z5):	(Z5):	(Z5):	___/___/___ (000 to 255) x 10ms	Hardwire Zone 5 Speed
[046] Zone 6	(Z1 with ATZ):	(Z6):	(Z6):	___/___/___ (000 to 255) x 10ms	Hardwire Zone 6 Speed
[047] Zone 7	(Z2 with ATZ):	(Z7):	(Z7):	___/___/___ (000 to 255) x 10ms	Hardwire Zone 7 Speed
[048] Zone 8	(Z3 with ATZ):	(Z8):	(Z8):	___/___/___ (000 to 255) x 10ms	Hardwire Zone 8 Speed
[049] Zone 9	(Z4 with ATZ):	(Z1 with ATZ):	(Z9):	___/___/___ (000 to 255) x 10ms	Hardwire Zone 9 Speed
[050] Zone 10	(Z5 with ATZ):	(Z2 with ATZ):	(Z10):	___/___/___ (000 to 255) x 10ms	Hardwire Zone 11 Speed
[051] Zone 11		(Z3 with ATZ):	(Z11):	___/___/___ (000 to 255) x 10ms	Hardwire Zone 12 Speed
[052] Zone 12		(Z4 with ATZ):	(Z12):	___/___/___ (000 to 255) x 10ms	Hardwire Zone 13 Speed
[053] Zone 13		(Z5 with ATZ):	(Z13):	___/___/___ (000 to 255) x 10ms	Hardwire Zone 14 Speed
[054] Zone 14		(Z6 with ATZ):	(Z14):	___/___/___ (000 to 255) x 10ms	Hardwire Zone 15 Speed
[055] Zone 15		(Z7 with ATZ):	(Z15):	___/___/___ (000 to 255) x 10ms	Hardwire Zone 16 Speed
[056] Zone 16		(Z8 with ATZ):	(Z16):	___/___/___ (000 to 255) x 10ms	Hardwire Zone 17 Speed

## Wireless Transmitter Signal Strength

Section	Section	Section	Section
[101] Zone 1	[109] Zone 9	[117] Zone 17	[125] Zone 25
[102] Zone 2	[110] Zone 10	[118] Zone 18	[126] Zone 26
[103] Zone 3	[111] Zone 11	[119] Zone 19	[127] Zone 27
[104] Zone 4	[112] Zone 12	[120] Zone 20	[128] Zone 28
[105] Zone 5	[113] Zone 13	[121] Zone 21	[129] Zone 29
[106] Zone 6	[114] Zone 14	[122] Zone 22	[130] Zone 30
[107] Zone 7	[115] Zone 15	[123] Zone 23	[131] Zone 31
[108] Zone 8	[116] Zone 16	[124] Zone 24	[132] Zone 32

<b>Signal Strength Indicator</b>	8 to 10 / 3 beeps = Best signal	5 to 7 / 2 beeps = Average signal	1 to 4 / 1 beep = Weak signal (Relocate)
----------------------------------	---------------------------------	-----------------------------------	--



To view the wireless transmitter signal strength, press the wireless transmitter's anti-tamper switch while in the respective section.

## Zone Reporting Codes (Default = FF)

Section	Alarm	Alarm Restore	Tamper	Tamper Restore
[141] Zone 1:	___/___	___/___	___/___	___/___
[142] Zone 2:	___/___	___/___	___/___	___/___
[143] Zone 3:	___/___	___/___	___/___	___/___
[144] Zone 4:	___/___	___/___	___/___	___/___
[145] Zone 5:	___/___	___/___	___/___	___/___
[146] Zone 6:	___/___	___/___	___/___	___/___
[147] Zone 7:	___/___	___/___	___/___	___/___
[148] Zone 8:	___/___	___/___	___/___	___/___
[149] Zone 9:	___/___	___/___	___/___	___/___
[150] Zone 10:	___/___	___/___	___/___	___/___
[151] Zone 11:	___/___	___/___	___/___	___/___
[152] Zone 12:	___/___	___/___	___/___	___/___
[153] Zone 13:	___/___	___/___	___/___	___/___
[154] Zone 14:	___/___	___/___	___/___	___/___
[155] Zone 15:	___/___	___/___	___/___	___/___
[156] Zone 16:	___/___	___/___	___/___	___/___
[157] Zone 17:	___/___	___/___	___/___	___/___
[158] Zone 18:	___/___	___/___	___/___	___/___
[159] Zone 19:	___/___	___/___	___/___	___/___
[160] Zone 20:	___/___	___/___	___/___	___/___
[161] Zone 21:	___/___	___/___	___/___	___/___
[162] Zone 22:	___/___	___/___	___/___	___/___
[163] Zone 23:	___/___	___/___	___/___	___/___
[164] Zone 24:	___/___	___/___	___/___	___/___
[165] Zone 25:	___/___	___/___	___/___	___/___
[166] Zone 26:	___/___	___/___	___/___	___/___
[167] Zone 27:	___/___	___/___	___/___	___/___
[168] Zone 28:	___/___	___/___	___/___	___/___
[169] Zone 29:	___/___	___/___	___/___	___/___
[170] Zone 30:	___/___	___/___	___/___	___/___
[171] Zone 31:	___/___	___/___	___/___	___/___
[172] Zone 32:	___/___	___/___	___/___	___/___



Refer to *Decimal and Hexadecimal Values* on page 41.

# Programmable Output Programming

## Programmable Output Activation/Deactivation Events

	Section	Event Group #	Sub-Group #	Partition # (99 for both partitions)	Default
[220]	PGM 1: Activation Event	( ___/___ )	( ___/___ )	( ___/___ )	08/99/99*
[221]	Deactivation Event	( ___/___ )	( ___/___ )	( ___/___ )	00/00/00
[222]	PGM 2: Activation Event	( ___/___ )	( ___/___ )	( ___/___ )	09/99/99†
[223]	Deactivation Event	( ___/___ )	( ___/___ )	( ___/___ )	00/00/00
[224]	PGM 3: Activation Event	( ___/___ )	( ___/___ )	( ___/___ )	00/00/00
[225]	Deactivation Event	( ___/___ )	( ___/___ )	( ___/___ )	00/00/00
[226]	PGM 4: Activation Event	( ___/___ )	( ___/___ )	( ___/___ )	00/00/00
[227]	Deactivation Event	( ___/___ )	( ___/___ )	( ___/___ )	00/00/00
[228]	PGM 5: Activation Event	( ___/___ )	( ___/___ )	( ___/___ )	00/00/00
[229]	Deactivation Event	( ___/___ )	( ___/___ )	( ___/___ )	00/00/00
[230]	PGM 6: Activation Event	( ___/___ )	( ___/___ )	( ___/___ )	00/00/00
[231]	Deactivation Event	( ___/___ )	( ___/___ )	( ___/___ )	00/00/00
[232]	PGM 7: Activation Event	( ___/___ )	( ___/___ )	( ___/___ )	00/00/00
[233]	Deactivation Event	( ___/___ )	( ___/___ )	( ___/___ )	00/00/00
[234]	PGM 8: Activation Event	( ___/___ )	( ___/___ )	( ___/___ )	00/00/00
[235]	Deactivation Event	( ___/___ )	( ___/___ )	( ___/___ )	00/00/00
[236]	PGM 9: Activation Event	( ___/___ )	( ___/___ )	( ___/___ )	00/00/00
[237]	Deactivation Event	( ___/___ )	( ___/___ )	( ___/___ )	00/00/00
[238]	PGM 10: Activation Event	( ___/___ )	( ___/___ )	( ___/___ )	00/00/00
[239]	Deactivation Event	( ___/___ )	( ___/___ )	( ___/___ )	00/00/00
[240]	PGM 11: Activation Event	( ___/___ )	( ___/___ )	( ___/___ )	00/00/00
[241]	Deactivation Event	( ___/___ )	( ___/___ )	( ___/___ )	00/00/00
[242]	PGM 12: Activation Event	( ___/___ )	( ___/___ )	( ___/___ )	00/00/00
[243]	Deactivation Event	( ___/___ )	( ___/___ )	( ___/___ )	00/00/00
[244]	PGM 13: Activation Event	( ___/___ )	( ___/___ )	( ___/___ )	00/00/00
[245]	Deactivation Event	( ___/___ )	( ___/___ )	( ___/___ )	00/00/00
[246]	PGM 14: Activation Event	( ___/___ )	( ___/___ )	( ___/___ )	00/00/00
[247]	Deactivation Event	( ___/___ )	( ___/___ )	( ___/___ )	00/00/00
[248]	PGM 15: Activation Event	( ___/___ )	( ___/___ )	( ___/___ )	00/00/00
[249]	Deactivation Event	( ___/___ )	( ___/___ )	( ___/___ )	00/00/00
[250]	PGM 16: Activation Event	( ___/___ )	( ___/___ )	( ___/___ )	00/00/00
[251]	Deactivation Event	( ___/___ )	( ___/___ )	( ___/___ )	00/00/00

 \* Section [220] PGM 1 Activation Event **default** = (Option B Remote Assignment) Button pressed on Any remote/Any partition.  
 † Section [222] PGM 2 Activation Event **default** = (Option C Remote Assignment) Button pressed on Any remote/Any partition.  
**See Button Options Table on page 23.**

## Event Description

Event Group #	Sub-group #
<b>00 = Zone OK</b> <b>01 = Zone open</b>	01 to 32 = Zone number 99 = Any zone number
<b>02 = Partition status</b>	00 to 01= N/A 02 = Silent alarm 03 = Buzzer alarm 04 = Steady alarm 05 = Pulsed alarm 06 = Strobe 07 = Alarm stopped 08 = Squawk ON (Partition 1 only) 09 = Squawk OFF (Partition 1 only) 10 = Ground start (Partition 1 only) 11 = Disarm partition 12 = Arm partition 13 = Entry delay started 14 = Exit delay started 99 = Any partition status event
<b>03 = Bell status (Partition 1 only)</b>	00 = Bell OFF 01 = Bell ON 02 = Bell squawk arm 03 = Bell squawk disarm 99 = Any bell status event
<b>06 = Non-reportable event</b>	00 = Telephone line trouble 01 = [ENTER] / [CLEAR] / [⏻] key was pressed (Partition 1 only) 02 = N/A 03 = Arm in stay mode 04 = Arm in sleep mode 05 = Arm in force mode 06 = Full arm when armed in stay mode 07 = PC fail to communicate (Partition 1 only) 08 = Utility Key 1 pressed (keys [1] and [2]) (Partition 1 only) 09 = Utility Key 2 pressed (keys [2] and [3]) (Partition 1 only) 10 = Utility Key 3 pressed (keys [4] and [5]) (Partition 1 only) 11 = Utility Key 4 pressed (keys [5] and [6]) (Partition 1 only) 12 = Utility Key 5 pressed (keys [7] and [8]) (Partition 1 only) 13 = Utility Key 6 pressed (keys [8] and [9]) (Partition 1 only) 14 = Tamper generated alarm 15 = Supervision loss generated alarm 16 = N/A 17 = N/A 18 = N/A 19 = N/A 20 = Full arm when armed in sleep mode 21 = Firmware upgrade (Partition 1 only) 99 = Any non-reportable event
<b>07 = Remote control access</b> <b>08 = Button pressed on remote</b> (See button option "B" on page 23) <b>09 = Button pressed on remote</b> (See button option "C" on page 23) <b>10 = Button pressed on remote</b> (See button option "D" on page 23) <b>11 = Button pressed on remote</b> (See button option "E" on page 23)	01 to 32 = Remote control number 99 = Any remote control number
<b>12 = Cold start wireless zone</b>	01 to 32 = Zone number 99 = Any zone number

Event Group #	Sub-group #
<b>13 = Cold start wireless module (Partition 1 only)</b>	01 to 16 = Output number 17 to 18 = Wireless repeater 19 to 22 = Wireless keypad 99 = Any output number
<b>14 = Bypass programming</b> <b>15 = User code activated output (Partition 1 only)</b>	01 to 32 = User number 99 = Any user number
<b>16 = Wireless smoke maintenance signal</b> <b>17 = Delay zone alarm transmission</b> <b>18 = Zone signal strength weak 1 (Partition 1 only)</b> <b>19 = Zone signal strength weak 2 (Partition 1 only)</b> <b>20 = Zone signal strength weak 3 (Partition 1 only)</b> <b>21 = Zone signal strength weak 4 (Partition 1 only)</b>	01 to 32 = Zone number 99 = Any zone number
<b>24 = Fire Delay started</b>	01 to 32 = Zone number 99 = Any zone number
<b>25 to 26 = N/A</b>	
<b>27 = Bus module event</b>	00 = A bus module was added 01 = A bus module was removed 02 = 2-way RF Module Communication Failure 03 = 2-way RF Module Communication Restored
<b>28 = StayD pass acknowledged</b>	01 to 32 = Zone number 99 = Any zone number
<b>29 = Arming with user</b>	01 to 32 = User number 99 = Any user number
<b>30 = Special arming</b>	00 = Auto-arming (on time/no movement) 01 = Late to close 02 = No movement arming 03 = Partial arming 04 = Quick arming 05 = Arming through WinLoad 99 = Any special arming
<b>31 = Disarming with user</b> <b>32 = Disarming after alarm with user</b> <b>33 = Alarm cancelled with user</b>	01 to 32 = User number 99 = Any user number
<b>34 = Special disarming</b>	00 = Auto-arm cancelled (on time/no movement) 01 = Disarming through WinLoad 02 = Disarming through WinLoad after alarm 03 = Alarm cancelled through WinLoad 04 = Paramedical alarm cancelled 99 = Any special disarming
<b>35 = Zone bypassed</b> <b>36 = Zone in alarm</b> <b>37 = Fire alarm</b> <b>38 = Zone alarm restore</b> <b>39 = Fire alarm restore</b>	01 to 32 = Zone number 99 = Any zone number
<b>40 = Special alarm</b>	00 = Panic non-medical emergency 01 = Panic medical (this panic alarm is not UL approved) 02 = Panic fire 03 = Recent closing 04 = Global shutdown 05 = Duress alarm 06 = Keypad lockout (Partition 1 only) 99 = Any special alarm event
<b>41 = Zone shutdown</b> <b>42 = Zone tampered</b> <b>43 = Zone tamper restore</b>	01 to 32 = Zone number 99 = Any zone number



Event Group #	Sub-group #
<b>44 = New trouble (Partition 1 only except sub-group 07 = both partitions)</b>	00 = N/A 01 = AC failure 02 = Battery failure 03 = Auxiliary current overload 04 = Bell current overload 05 = Bell disconnected 06 = Clock loss 07 = Fire loop trouble 08 = Fail to communicate to monitoring station telephone #1 09 = Fail to communicate to monitoring station telephone #2 10 = Fail to communicate to pager report 11 = Fail to communicate to voice report 12 = RF interference 99 = Any new trouble event
<b>45 = Trouble restored</b>	00 = Telephone line restored 01 = AC failure restore 02 = Battery failure restore 03 = Auxiliary current overload restore 04 = Bell current overload restore 05 = Bell disconnected restore 06 = Clock loss restore 07 = Fire loop trouble restore 12 = RF interference restore 99 = Any trouble restored event
<b>46 = Bus/wireless module new trouble (Partition 1 only)</b>	00 = Bus communication fault 01 = Tamper trouble 02 = Power fail 03 = Battery failure 99 = Any bus module new trouble event
<b>47 = Bus/wireless module trouble restored (Partition 1 only)</b>	00 = Bus communication fault restore 01 = Tamper trouble restore 02 = Power fail 03 = Battery failure 99 = Any bus module trouble restored event
<b>48 = Special (Partition 1 only)</b>	00 = System power up 01 = Reporting test 02 = WinLoad log on 03 = WinLoad log off 04 = Installer in programming mode 05 = Installer exited programming mode 06 = Maintenance in programming mode 07 = Maintenance exited programming mode 08 = Closing delinquency delay elapsed 99 = Any special event
<b>49 = Low battery on zone 50 = Low battery on zone restore 51 = Zone supervision trouble 52 = Zone supervision restore</b>	01 to 32 = Zone number 99 = Any zone number
<b>53 = Wireless module supervision trouble (Partition 1 only) 54 = Wireless module supervision restore (Partition 1 only) 55 = Wireless module tamper trouble (Partition 1 only) 56 = Wireless module tamper restore (Partition 1 only)</b>	01 to 16 = Output 17 to 18 = Wireless repeater 19 to 22 = Wireless keypad
<b>57 = Non-medical alarm (paramedic)</b>	01 to 32 = User number 99 = Any user number
<b>58 = Zone forced 59 = Zone included</b>	01 to 32 = Zone number 99 = Any zone number



Refer to the **Installer Quick Menu** on page 3 for alternate PGM programming.

## Programmable Output Options

Default: <b>Bold</b>		Section:		PGM 1 [261]		PGM 2 [262]		PGM 3 [263]		PGM 4 [264]	
Option		OFF	ON	OFF	ON	OFF	ON	OFF	ON	OFF	ON
[1]	PGM Base Time (Off=Sec; On=Min)	<input type="checkbox"/>	<input type="checkbox"/>	<input type="checkbox"/>	<input type="checkbox"/>	<input type="checkbox"/>	<input type="checkbox"/>	<input type="checkbox"/>	<input type="checkbox"/>	<input type="checkbox"/>	<input type="checkbox"/>
[2]	PGM State (Off=N.O., On=N.C.)	<input type="checkbox"/>	<input type="checkbox"/>	<input type="checkbox"/>	<input type="checkbox"/>	<input type="checkbox"/>	<input type="checkbox"/>	<input type="checkbox"/>	<input type="checkbox"/>	<input type="checkbox"/>	<input type="checkbox"/>
[3]	PGM Supervision	<input type="checkbox"/>	<input checked="" type="checkbox"/>	<input type="checkbox"/>	<input checked="" type="checkbox"/>	<input type="checkbox"/>	<input checked="" type="checkbox"/>	<input type="checkbox"/>	<input checked="" type="checkbox"/>	<input type="checkbox"/>	<input checked="" type="checkbox"/>
[4]	PGM Activation Mode (Off=Steady, On=Pulse)	<input type="checkbox"/>	<input type="checkbox"/>	<input type="checkbox"/>	<input type="checkbox"/>	<input type="checkbox"/>	<input type="checkbox"/>	<input type="checkbox"/>	<input type="checkbox"/>	<input type="checkbox"/>	<input type="checkbox"/>
[5]	PGM Pulse once every 30 seconds if armed	<input type="checkbox"/>	<input type="checkbox"/>	<input type="checkbox"/>	<input type="checkbox"/>	<input type="checkbox"/>	<input type="checkbox"/>	<input type="checkbox"/>	<input type="checkbox"/>	<input type="checkbox"/>	<input type="checkbox"/>
[6]	PGM Pulse on any alarm	<input type="checkbox"/>	<input type="checkbox"/>	<input type="checkbox"/>	<input type="checkbox"/>	<input type="checkbox"/>	<input type="checkbox"/>	<input type="checkbox"/>	<input type="checkbox"/>	<input type="checkbox"/>	<input type="checkbox"/>
[7]	PGM Pulse on any alarm - OFF= Partition 1 On= Partition 2	<input type="checkbox"/>	<input type="checkbox"/>	<input type="checkbox"/>	<input type="checkbox"/>	<input type="checkbox"/>	<input type="checkbox"/>	<input type="checkbox"/>	<input type="checkbox"/>	<input type="checkbox"/>	<input type="checkbox"/>
[8]	N/A	N/A	N/A	N/A	N/A	N/A	N/A	N/A	N/A	N/A	N/A

Default: <b>Bold</b>		Section:		PGM 5 [265]		PGM 6 [266]		PGM 7 [267]		PGM 8 [268]	
Option		OFF	ON	OFF	ON	OFF	ON	OFF	ON	OFF	ON
[1]	PGM Base Time (Off=Sec.; On=Min.)	<input type="checkbox"/>	<input type="checkbox"/>	<input type="checkbox"/>	<input type="checkbox"/>	<input type="checkbox"/>	<input type="checkbox"/>	<input type="checkbox"/>	<input type="checkbox"/>	<input type="checkbox"/>	<input type="checkbox"/>
[2]	PGM State (Off=N.O., On= N.C.)	<input type="checkbox"/>	<input type="checkbox"/>	<input type="checkbox"/>	<input type="checkbox"/>	<input type="checkbox"/>	<input type="checkbox"/>	<input type="checkbox"/>	<input type="checkbox"/>	<input type="checkbox"/>	<input type="checkbox"/>
[3]	PGM Supervision	<input type="checkbox"/>	<input checked="" type="checkbox"/>	<input type="checkbox"/>	<input checked="" type="checkbox"/>	<input type="checkbox"/>	<input checked="" type="checkbox"/>	<input type="checkbox"/>	<input checked="" type="checkbox"/>	<input type="checkbox"/>	<input checked="" type="checkbox"/>
[4]	PGM Activation Mode (Off=Steady, ON=Pulse)	<input type="checkbox"/>	<input type="checkbox"/>	<input type="checkbox"/>	<input type="checkbox"/>	<input type="checkbox"/>	<input type="checkbox"/>	<input type="checkbox"/>	<input type="checkbox"/>	<input type="checkbox"/>	<input type="checkbox"/>
[5]	PGM Pulse once every 30 seconds if armed	<input type="checkbox"/>	<input type="checkbox"/>	<input type="checkbox"/>	<input type="checkbox"/>	<input type="checkbox"/>	<input type="checkbox"/>	<input type="checkbox"/>	<input type="checkbox"/>	<input type="checkbox"/>	<input type="checkbox"/>
[6]	PGM Pulse on any alarm	<input type="checkbox"/>	<input type="checkbox"/>	<input type="checkbox"/>	<input type="checkbox"/>	<input type="checkbox"/>	<input type="checkbox"/>	<input type="checkbox"/>	<input type="checkbox"/>	<input type="checkbox"/>	<input type="checkbox"/>
[7]	PGM Pulse on any alarm - OFF= Partition 1 On= Partition 2	<input type="checkbox"/>	<input type="checkbox"/>	<input type="checkbox"/>	<input type="checkbox"/>	<input type="checkbox"/>	<input type="checkbox"/>	<input type="checkbox"/>	<input type="checkbox"/>	<input type="checkbox"/>	<input type="checkbox"/>
[8]	N/A	N/A	N/A	N/A	N/A	N/A	N/A	N/A	N/A	N/A	N/A

Default: <b>Bold</b>		Section:		PGM 9 [269]		PGM 10 [270]		PGM 11 [271]		PGM 12 [272]	
Option		OFF	ON	OFF	ON	OFF	ON	OFF	ON	OFF	ON
[1]	PGM Base Time (Off=Sec; On=Min)	<input type="checkbox"/>	<input type="checkbox"/>	<input type="checkbox"/>	<input type="checkbox"/>	<input type="checkbox"/>	<input type="checkbox"/>	<input type="checkbox"/>	<input type="checkbox"/>	<input type="checkbox"/>	<input type="checkbox"/>
[2]	PGM State (Off=N.O., On=N.C.)	<input type="checkbox"/>	<input type="checkbox"/>	<input type="checkbox"/>	<input type="checkbox"/>	<input type="checkbox"/>	<input type="checkbox"/>	<input type="checkbox"/>	<input type="checkbox"/>	<input type="checkbox"/>	<input type="checkbox"/>
[3]	PGM Supervision	<input type="checkbox"/>	<input checked="" type="checkbox"/>	<input type="checkbox"/>	<input checked="" type="checkbox"/>	<input type="checkbox"/>	<input checked="" type="checkbox"/>	<input type="checkbox"/>	<input checked="" type="checkbox"/>	<input type="checkbox"/>	<input checked="" type="checkbox"/>
[4]	PGM Activation Mode (Off=Steady, On=Pulse)	<input type="checkbox"/>	<input type="checkbox"/>	<input type="checkbox"/>	<input type="checkbox"/>	<input type="checkbox"/>	<input type="checkbox"/>	<input type="checkbox"/>	<input type="checkbox"/>	<input type="checkbox"/>	<input type="checkbox"/>
[5]	PGM Pulse once every 30 seconds if armed	<input type="checkbox"/>	<input type="checkbox"/>	<input type="checkbox"/>	<input type="checkbox"/>	<input type="checkbox"/>	<input type="checkbox"/>	<input type="checkbox"/>	<input type="checkbox"/>	<input type="checkbox"/>	<input type="checkbox"/>
[6]	PGM Pulse on any alarm	<input type="checkbox"/>	<input type="checkbox"/>	<input type="checkbox"/>	<input type="checkbox"/>	<input type="checkbox"/>	<input type="checkbox"/>	<input type="checkbox"/>	<input type="checkbox"/>	<input type="checkbox"/>	<input type="checkbox"/>
[7]	PGM Pulse on any alarm - OFF= Partition 1 On= Partition 2	<input type="checkbox"/>	<input type="checkbox"/>	<input type="checkbox"/>	<input type="checkbox"/>	<input type="checkbox"/>	<input type="checkbox"/>	<input type="checkbox"/>	<input type="checkbox"/>	<input type="checkbox"/>	<input type="checkbox"/>
[8]	N/A	N/A	N/A	N/A	N/A	N/A	N/A	N/A	N/A	N/A	N/A

Default: Bold Option	Section:	PGM 13 [273]		PGM 14 [274]		PGM 15 [275]		PGM 16 [276]	
		OFF	ON	OFF	ON	OFF	ON	OFF	ON
[1]	PGM Base Time (Off=Sec; On=Min)	<input type="checkbox"/>	<input type="checkbox"/>	<input type="checkbox"/>	<input type="checkbox"/>	<input type="checkbox"/>	<input type="checkbox"/>	<input type="checkbox"/>	<input type="checkbox"/>
[2]	PGM State (Off=N.O., On=N.C.)	<input type="checkbox"/>	<input type="checkbox"/>	<input type="checkbox"/>	<input type="checkbox"/>	<input type="checkbox"/>	<input type="checkbox"/>	<input type="checkbox"/>	<input type="checkbox"/>
[3]	PGM Supervision	<input type="checkbox"/>	<input checked="" type="checkbox"/>	<input type="checkbox"/>	<input checked="" type="checkbox"/>	<input type="checkbox"/>	<input checked="" type="checkbox"/>	<input type="checkbox"/>	<input checked="" type="checkbox"/>
[4]	PGM Activation Mode (Off=Steady, On=Pulse)	<input type="checkbox"/>	<input type="checkbox"/>	<input type="checkbox"/>	<input type="checkbox"/>	<input type="checkbox"/>	<input type="checkbox"/>	<input type="checkbox"/>	<input type="checkbox"/>
[5]	PGM Pulse once every 30 seconds if armed	<input type="checkbox"/>	<input type="checkbox"/>	<input type="checkbox"/>	<input type="checkbox"/>	<input type="checkbox"/>	<input type="checkbox"/>	<input type="checkbox"/>	<input type="checkbox"/>
[6]	PGM Pulse on any alarm	<input type="checkbox"/>	<input type="checkbox"/>	<input type="checkbox"/>	<input type="checkbox"/>	<input type="checkbox"/>	<input type="checkbox"/>	<input type="checkbox"/>	<input type="checkbox"/>
[7]	PGM Pulse on any alarm - OFF= Partition 1 On= Partition 2	<input type="checkbox"/>	<input type="checkbox"/>	<input type="checkbox"/>	<input type="checkbox"/>	<input type="checkbox"/>	<input type="checkbox"/>	<input type="checkbox"/>	<input type="checkbox"/>
[8]	N/A	N/A	N/A	N/A	N/A	N/A	N/A	N/A	N/A

## Programmable Output Delays

Section	MG5000/SP5500 Data	Default = 005	MG5050/SP6000/SP7000 Data	Default = 005
[281]	PGM 1†: ___/___/___ (000 to 255 x 1 sec./mins.)		___/___/___ (000 to 255 x 1 sec./mins.)	
[282]	PGM 2†: ___/___/___ (000 to 255 x 1 sec./mins.)		___/___/___ (000 to 255 x 1 sec./mins.)	
[283]	PGM 3†: ___/___/___ (001 / 005 / 015 / 030 x 1 sec./mins.)		___/___/___ (000 to 255 x 1 sec./mins.)	
[284]	PGM 4†: ___/___/___ (001 / 005 / 015 / 030 x 1 sec./mins.)		___/___/___ (000 to 255 x 1 sec./mins.)	
[285]	PGM 5: ___/___/___ (001 / 005 / 015 / 030 x 1 sec./mins.)		___/___/___ (001 / 005 / 015 / 030 x 1 sec./mins.)	
[286]	PGM 6: ___/___/___ (001 / 005 / 015 / 030 x 1 sec./mins.)		___/___/___ (001 / 005 / 015 / 030 x 1 sec./mins.)	
[287]	PGM 7: ___/___/___ (001 / 005 / 015 / 030 x 1 sec./mins.)		___/___/___ (001 / 005 / 015 / 030 x 1 sec./mins.)	
[288]	PGM 8: ___/___/___ (001 / 005 / 015 / 030 x 1 sec./mins.)		___/___/___ (001 / 005 / 015 / 030 x 1 sec./mins.)	
[289]	PGM 9: ___/___/___ (001 / 005 / 015 / 030 x 1 sec./mins.)		___/___/___ (001 / 005 / 015 / 030 x 1 sec./mins.)	
[290]	PGM 10: ___/___/___ (001 / 005 / 015 / 030 x 1 sec./mins.)		___/___/___ (001 / 005 / 015 / 030 x 1 sec./mins.)	
[291]	PGM 11: ___/___/___ (001 / 005 / 015 / 030 x 1 sec./mins.)		___/___/___ (001 / 005 / 015 / 030 x 1 sec./mins.)	
[292]	PGM 12: ___/___/___ (001 / 005 / 015 / 030 x 1 sec./mins.)		___/___/___ (001 / 005 / 015 / 030 x 1 sec./mins.)	
[293]	PGM 13: ___/___/___ (001 / 005 / 015 / 030 x 1 sec./mins.)		___/___/___ (001 / 005 / 015 / 030 x 1 sec./mins.)	
[294]	PGM 14: ___/___/___ (001 / 005 / 015 / 030 x 1 sec./mins.)		___/___/___ (001 / 005 / 015 / 030 x 1 sec./mins.)	
[295]	PGM 15: ___/___/___ (001 / 005 / 015 / 030 x 1 sec./mins.)		___/___/___ (001 / 005 / 015 / 030 x 1 sec./mins.)	
[296]	PGM 16: ___/___/___ (001 / 005 / 015 / 030 x 1 sec./mins.)		___/___/___ (001 / 005 / 015 / 030 x 1 sec./mins.)	

\* = hardwired (MG5000/SP5500) † = hardwired (MG5050/SP6000/SP7000)

## PGMs Serial Number

Section	Wireless PGM Serial Number	Section	Wireless PGM Serial Number
[301]	PGM 1: ___/___/___/___/___/___	[309]	PGM 9: ___/___/___/___/___/___
[302]	PGM 2: ___/___/___/___/___/___	[310]	PGM 10: ___/___/___/___/___/___
[303]	PGM 3: ___/___/___/___/___/___	[311]	PGM 11: ___/___/___/___/___/___
[304]	PGM 4: ___/___/___/___/___/___	[312]	PGM 12: ___/___/___/___/___/___
[305]	PGM 5: ___/___/___/___/___/___	[313]	PGM 13: ___/___/___/___/___/___
[306]	PGM 6: ___/___/___/___/___/___	[314]	PGM 14: ___/___/___/___/___/___
[307]	PGM 7: ___/___/___/___/___/___	[315]	PGM 15: ___/___/___/___/___/___
[308]	PGM 8: ___/___/___/___/___/___	[316]	PGM 16: ___/___/___/___/___/___



To delete a wireless PGM, enter [000000] in its respective section.

To view the serial number display, refer to section [960].

For automatic assignment, press the PGM's anti-tamper switch while in the respective section.



Refer to the **Installer Quick Menu** on page 3 for alternate PGM programming.

## Wireless PGM Signal Strength

Section	Section
[321] PGM 1 Wireless PGM Signal Strength	[329] PGM 9 Wireless PGM Signal Strength
[322] PGM 2 Wireless PGM Signal Strength	[330] PGM 10 Wireless PGM Signal Strength
[323] PGM 3 Wireless PGM Signal Strength	[331] PGM 11 Wireless PGM Signal Strength
[324] PGM 4 Wireless PGM Signal Strength	[332] PGM 12 Wireless PGM Signal Strength
[325] PGM 5 Wireless PGM Signal Strength	[333] PGM 13 Wireless PGM Signal Strength
[326] PGM 6 Wireless PGM Signal Strength	[334] PGM 14 Wireless PGM Signal Strength
[327] PGM 7 Wireless PGM Signal Strength	[335] PGM 15 Wireless PGM Signal Strength
[328] PGM 8 Wireless PGM Signal Strength	[336] PGM 16 Wireless PGM Signal Strength

Signal Strength Indicator	8 to 10 / 3 beeps = Best signal	5 to 7 / 2 beeps = Average signal	1 to 4 / 1 beep = Weak signal (Relocate)
---------------------------	---------------------------------	-----------------------------------	--



To view the wireless PGM signal strength, press the wireless PGM's anti-tamper switch while in the respective section.

## PGM Recognition

	MG5000/SP5500	MG5050/SP6000/SP7000
PGM 1	Control Panel Output 1	Control Panel Output 1
PGM 2	Control Panel Output 2	Control Panel Output 2
PGM 3	N/A	Control Panel Output 3
PGM 4	N/A	Control Panel Output 4
PGM 5	N/A	Control Panel Relay
PGM 6	ZX8 ID= 1 Output	ZX8 ID= 1 Output
PGM 7	ZX8 ID= 2 Output	ZX8 ID= 2 Output
PGM 8	ZX8 ID= 3 Output	ZX8 ID= 3 Output
PGM 9	PGM4 Output 1	PGM4 Output 1
PGM 10	PGM4 Output 2	PGM4 Output 2
PGM 11	PGM4 Output 3	PGM4 Output 3
PGM 12	PGM4 Output 4	PGM4 Output 4
PGM 13	RTX3 Output 1	RTX3 Output 1
PGM 14	RTX3 Output 2	RTX3 Output 2
PGM 15	RTX3 Output 3	RTX3 Output 3
PGM 16	RTX3 Output 4	RTX3 Output 4



A Wireless PGM module can be assigned to any PGM. It will work in parallel with the Control Panel Output.

# User Programming



Refer to the **Installer Quick Menu** on page 3 for installer or maintenance code programming.  
Refer to the **Master Quick Menu** in the User Guide for user code/remote control programming.

## System Codes

Section	Data	Description
[395]	___/___/___ (147 to lock, other to unlock)	Installer Code Lock (default 000)
[397]	___/___/___/___/___/___	Installer Code (default = 000000)*
[398]	___/___/___/___/___/___	Maintenance Code (default = 111111)*
[399]	___/___/___/___/___/___	System Master Code (default = 123456)*

\*4 or 6 digits according to section [701] option [1]. The control panel automatically removes the last 2 digits of the user access code if the length is changed from 6 digits to 4 digits. However, if the user access code length is changed from 4 to 6 digits, the control panel adds 2 digits to the end by using the first two digits.

Maintenance Code Limited Access Table			
These are the sections that the Maintenance Code cannot access:			
[395]	Installer code lock	[816]	Monitoring station telephone number 2
[397]	Installer code	[817]	Backup monitoring station telephone
[398]	Maintenance code	[910]	Panel ID
[815]	Monitoring station telephone number 1	[911]	PC password

## User Code Options

### User Options

1 - Partition 1 Access

2 - Partition 2 Access

3 - Bypass Programming

4 - Stay/Sleep Arming

5 - Force Arming (Regular/Sleep/StayArming)

6 - Arm Only

7 - PGM Activation Only

8 - Duress

 **When section [400] is accessed, the panel will copy the saved value of that section to all user options- [404] to [432].**

Section	Options	Section	Options
[400] Default Option	1 2 3 4 5 6 7 8	[417] User 17:	1 2 3 4 5 6 7 8
[401] System Master:	1 2 3 4 5 6 7 8	[418] User 18:	1 2 3 4 5 6 7 8
[402] Master 1:	1 2 3 4 5 6 7 8	[419] User 19:	1 2 3 4 5 6 7 8
[403] Master 2:	1 2 3 4 5 6 7 8	[420] User 20:	1 2 3 4 5 6 7 8
[404] User 4:	① ② ③ ④ ⑤ 6 7 8	[421] User 21:	1 2 3 4 5 6 7 8
[405] User 5:	① 2 ③ ④ ⑤ 6 7 8	[422] User 22:	1 2 3 4 5 6 7 8
[406] User 6:	1 ② ③ ④ ⑤ 6 7 8	[423] User 23:	1 2 3 4 5 6 7 8
[407] User 7:	1 2 3 4 5 6 7 8	[424] User 24:	1 2 3 4 5 6 7 8
[408] User 8:	1 2 3 4 5 6 7 8	[425] User 25:	1 2 3 4 5 6 7 8
[409] User 9:	1 2 3 4 5 6 7 8	[426] User 26:	1 2 3 4 5 6 7 8
[410] User 10:	1 2 3 4 5 6 7 8	[427] User 27:	1 2 3 4 5 6 7 8
[411] User 11:	1 2 3 4 5 6 7 8	[428] User 28:	1 2 3 4 5 6 7 8
[412] User 12:	1 2 3 4 5 6 7 8	[429] User 29:	1 2 3 4 5 6 7 8
[413] User 13:	1 2 3 4 5 6 7 8	[430] User 30:	1 2 3 4 5 6 7 8
[414] User 14:	1 2 3 4 5 6 7 8	[431] User 31:	1 2 3 4 5 6 7 8
[415] User 15:	1 2 3 4 5 6 7 8	[432] User 32:	1 2 3 4 5 6 7 8
[416] User 16:	1 2 3 4 5 6 7 8		

 The System Master, Master 1, and Master 2 user code options cannot be modified. However, if partitioning is not enabled, the user code options for Master 2 will match those of Master 1.

## User Reporting Codes (Default = FF)

Section	Arming	Disarming/Cancel Alarm	Section	Arming	Disarming/Cancel Alarm
[471] S. Master:	___/___	___/___	[487] User 17:	___/___	___/___
[472] Master 1:	___/___	___/___	[488] User 18:	___/___	___/___
[473] Master 2:	___/___	___/___	[489] User 19:	___/___	___/___
[474] User 4:	___/___	___/___	[490] User 20:	___/___	___/___
[475] User 5:	___/___	___/___	[491] User 21:	___/___	___/___
[476] User 6:	___/___	___/___	[492] User 22:	___/___	___/___
[477] User 7:	___/___	___/___	[493] User 23:	___/___	___/___
[478] User 8:	___/___	___/___	[494] User 24:	___/___	___/___
[479] User 9:	___/___	___/___	[495] User 25:	___/___	___/___
[480] User 10:	___/___	___/___	[496] User 26:	___/___	___/___
[481] User 11:	___/___	___/___	[497] User 27:	___/___	___/___
[482] User 12:	___/___	___/___	[498] User 28:	___/___	___/___
[483] User 13:	___/___	___/___	[499] User 29:	___/___	___/___
[484] User 14:	___/___	___/___	[500] User 30:	___/___	___/___
[485] User 15:	___/___	___/___	[501] User 31:	___/___	___/___
[486] User 16:	___/___	___/___	[502] User 32:	___/___	___/___



Refer to *Decimal and Hexadecimal Values* on page 41.

## Remote Control (RC) User Assignment

Section	Remote Serial Number	Section	Remote Serial Number
[651] RC 1 for User 1:	___/___/___/___/___/___	[667] RC 17 for User 17:	___/___/___/___/___/___
[652] RC 2 for User 2:	___/___/___/___/___/___	[668] RC 18 for User 18:	___/___/___/___/___/___
[653] RC 3 for User 3:	___/___/___/___/___/___	[669] RC 19 for User 19:	___/___/___/___/___/___
[654] RC 4 for User 4:	___/___/___/___/___/___	[670] RC 20 for User 20:	___/___/___/___/___/___
[655] RC 5 for User 5:	___/___/___/___/___/___	[671] RC 21 for User 21:	___/___/___/___/___/___
[656] RC 6 for User 6:	___/___/___/___/___/___	[672] RC 22 for User 22:	___/___/___/___/___/___
[657] RC 7 for User 7:	___/___/___/___/___/___	[673] RC 23 for User 23:	___/___/___/___/___/___
[658] RC 8 for User 8:	___/___/___/___/___/___	[674] RC 24 for User 24:	___/___/___/___/___/___
[659] RC 9 for User 9:	___/___/___/___/___/___	[675] RC 25 for User 25:	___/___/___/___/___/___
[660] RC 10 for User 10:	___/___/___/___/___/___	[676] RC 26 for User 26:	___/___/___/___/___/___
[661] RC 11 for User 11:	___/___/___/___/___/___	[677] RC 27 for User 27:	___/___/___/___/___/___
[662] RC 12 for User 12:	___/___/___/___/___/___	[678] RC 28 for User 28:	___/___/___/___/___/___
[663] RC 13 for User 13:	___/___/___/___/___/___	[679] RC 29 for User 29:	___/___/___/___/___/___
[664] RC 14 for User 14:	___/___/___/___/___/___	[680] RC 30 for User 30:	___/___/___/___/___/___
[665] RC 15 for User 15:	___/___/___/___/___/___	[681] RC 31 for User 31:	___/___/___/___/___/___
[666] RC 16 for User 16:	___/___/___/___/___/___	[682] RC 32 for User 32:	___/___/___/___/___/___











To delete a remote control, enter [000000] in its respective section. To view the serial number display, refer to section [960]. This section of the programming guide is for viewing the assigned remote control's serial number only. For automatic assignment, press a button on the designated remote while in the respective section.



Refer to the **Master Quick Menu** in the User Guide for user code/remote control programming.

# Remote Button Assignment

 When section [610] is accessed, the panel will copy the saved value of that section to all remotes.

Section	RC#	Data (Default: 1BC_)				Section	RC#	Data (Default: 1BC_)			
											
[610]	Default	_____	_____	_____	_____	[627]	17	_____	_____	_____	_____
[611]	1	_____	_____	_____	_____	[628]	18	_____	_____	_____	_____
[612]	2	_____	_____	_____	_____	[629]	19	_____	_____	_____	_____
[613]	3	_____	_____	_____	_____	[630]	20	_____	_____	_____	_____
[614]	4	_____	_____	_____	_____	[631]	21	_____	_____	_____	_____
[615]	5	_____	_____	_____	_____	[632]	22	_____	_____	_____	_____
[616]	6	_____	_____	_____	_____	[633]	23	_____	_____	_____	_____
[617]	7	_____	_____	_____	_____	[634]	24	_____	_____	_____	_____
[618]	8	_____	_____	_____	_____	[635]	25	_____	_____	_____	_____
[619]	9	_____	_____	_____	_____	[636]	26	_____	_____	_____	_____
[620]	10	_____	_____	_____	_____	[637]	27	_____	_____	_____	_____
[621]	11	_____	_____	_____	_____	[638]	28	_____	_____	_____	_____
[622]	12	_____	_____	_____	_____	[639]	29	_____	_____	_____	_____
[623]	13	_____	_____	_____	_____	[640]	30	_____	_____	_____	_____
[624]	14	_____	_____	_____	_____	[641]	31	_____	_____	_____	_____
[625]	15	_____	_____	_____	_____	[642]	32	_____	_____	_____	_____
[626]	16	_____	_____	_____	_____						



**MG-REM1**



**MG-REM2**

### Button Options Table

**Empty\*** - Button disabled

- 1 - Regular/Regular Force arming
- 2 - Stay/Stay Force arming
- 3 - N/A
- 4 - Sleep/Sleep Force arming
- 5 - N/A
- 6 - N/A
- 7 - N/A
- 8 - Panic 1
- 9 - Panic 2
- A - Panic 3
- B - PGM Activation (Event Group #8, see PGM Programming)
- C - PGM Activation (Event Group #9, see PGM Programming)
- D - PGM Activation (Event Group #10, see PGM Programming)
- E - PGM Activation (Event Group #11, see PGM Programming)
- F - Paramedic alarm

\* If you do not enter a value for a button, that button is disabled.

 = Disarm Button  
(cannot be modified)

 Refer to *Decimal and Hexadecimal Values* on page 41.





Default:		MG-RPT1 #1		MG-RPT1 #2	
<b>Bold</b>		[553]		[563]	
		Section:			
Option		OFF	ON	OFF	ON
[1]	Repeat Wireless Zone 9 Signals	<input type="checkbox"/>	<input type="checkbox"/>	<input type="checkbox"/>	<input type="checkbox"/>
[2]	Repeat Wireless Zone 10 Signals	<input type="checkbox"/>	<input type="checkbox"/>	<input type="checkbox"/>	<input type="checkbox"/>
[3]	Repeat Wireless Zone 11 Signals	<input type="checkbox"/>	<input type="checkbox"/>	<input type="checkbox"/>	<input type="checkbox"/>
[4]	Repeat Wireless Zone 12 Signals	<input type="checkbox"/>	<input type="checkbox"/>	<input type="checkbox"/>	<input type="checkbox"/>
[5]	Repeat Wireless Zone 13 Signals	<input type="checkbox"/>	<input type="checkbox"/>	<input type="checkbox"/>	<input type="checkbox"/>
[6]	Repeat Wireless Zone 14 Signals	<input type="checkbox"/>	<input type="checkbox"/>	<input type="checkbox"/>	<input type="checkbox"/>
[7]	Repeat Wireless Zone 15 Signals	<input type="checkbox"/>	<input type="checkbox"/>	<input type="checkbox"/>	<input type="checkbox"/>
[8]	Repeat Wireless Zone 16 Signals	<input type="checkbox"/>	<input type="checkbox"/>	<input type="checkbox"/>	<input type="checkbox"/>

Default:		MG-RPT1 #1		MG-RPT1 #2	
<b>Bold</b>		[554]		[564]	
		Section:			
Option		OFF	ON	OFF	ON
[1]	Repeat Wireless Zone 17 Signals	<input type="checkbox"/>	<input type="checkbox"/>	<input type="checkbox"/>	<input type="checkbox"/>
[2]	Repeat Wireless Zone 18 Signals	<input type="checkbox"/>	<input type="checkbox"/>	<input type="checkbox"/>	<input type="checkbox"/>
[3]	Repeat Wireless Zone 19 Signals	<input type="checkbox"/>	<input type="checkbox"/>	<input type="checkbox"/>	<input type="checkbox"/>
[4]	Repeat Wireless Zone 20 Signals	<input type="checkbox"/>	<input type="checkbox"/>	<input type="checkbox"/>	<input type="checkbox"/>
[5]	Repeat Wireless Zone 21 Signals	<input type="checkbox"/>	<input type="checkbox"/>	<input type="checkbox"/>	<input type="checkbox"/>
[6]	Repeat Wireless Zone 22 Signals	<input type="checkbox"/>	<input type="checkbox"/>	<input type="checkbox"/>	<input type="checkbox"/>
[7]	Repeat Wireless Zone 23 Signals	<input type="checkbox"/>	<input type="checkbox"/>	<input type="checkbox"/>	<input type="checkbox"/>
[8]	Repeat Wireless Zone 24 Signals	<input type="checkbox"/>	<input type="checkbox"/>	<input type="checkbox"/>	<input type="checkbox"/>

Default:		MG-RPT1 #1		MG-RPT1 #2	
<b>Bold</b>		[555]		[565]	
		Section:			
Option		OFF	ON	OFF	ON
[1]	Repeat Wireless Zone 25 Signals	<input type="checkbox"/>	<input type="checkbox"/>	<input type="checkbox"/>	<input type="checkbox"/>
[2]	Repeat Wireless Zone 26 Signals	<input type="checkbox"/>	<input type="checkbox"/>	<input type="checkbox"/>	<input type="checkbox"/>
[3]	Repeat Wireless Zone 27 Signals	<input type="checkbox"/>	<input type="checkbox"/>	<input type="checkbox"/>	<input type="checkbox"/>
[4]	Repeat Wireless Zone 28 Signals	<input type="checkbox"/>	<input type="checkbox"/>	<input type="checkbox"/>	<input type="checkbox"/>
[5]	Repeat Wireless Zone 29 Signals	<input type="checkbox"/>	<input type="checkbox"/>	<input type="checkbox"/>	<input type="checkbox"/>
[6]	Repeat Wireless Zone 30 Signals	<input type="checkbox"/>	<input type="checkbox"/>	<input type="checkbox"/>	<input type="checkbox"/>
[7]	Repeat Wireless Zone 31 Signals	<input type="checkbox"/>	<input type="checkbox"/>	<input type="checkbox"/>	<input type="checkbox"/>
[8]	Repeat Wireless Zone 32 Signals	<input type="checkbox"/>	<input type="checkbox"/>	<input type="checkbox"/>	<input type="checkbox"/>

Default:		MG-RPT1 #1		MG-RPT1 #2	
<b>Bold</b>	Section:	[556]		[566]	
Option		OFF	ON	OFF	ON
[1]	Repeat Wireless 2-Way PGM 1 Signals	<input type="checkbox"/>	<input type="checkbox"/>	<input type="checkbox"/>	<input type="checkbox"/>
[2]	Repeat Wireless 2-Way PGM 2 Signals	<input type="checkbox"/>	<input type="checkbox"/>	<input type="checkbox"/>	<input type="checkbox"/>
[3]	Repeat Wireless 2-Way PGM 3 Signals	<input type="checkbox"/>	<input type="checkbox"/>	<input type="checkbox"/>	<input type="checkbox"/>
[4]	Repeat Wireless 2-Way PGM 4 Signals	<input type="checkbox"/>	<input type="checkbox"/>	<input type="checkbox"/>	<input type="checkbox"/>
[5]	Repeat Wireless 2-Way PGM 5 Signals	<input type="checkbox"/>	<input type="checkbox"/>	<input type="checkbox"/>	<input type="checkbox"/>
[6]	Repeat Wireless 2-Way PGM 6 Signals	<input type="checkbox"/>	<input type="checkbox"/>	<input type="checkbox"/>	<input type="checkbox"/>
[7]	Repeat Wireless 2-Way PGM 7 Signals	<input type="checkbox"/>	<input type="checkbox"/>	<input type="checkbox"/>	<input type="checkbox"/>
[8]	Repeat Wireless 2-Way PGM 8 Signals	<input type="checkbox"/>	<input type="checkbox"/>	<input type="checkbox"/>	<input type="checkbox"/>

Default:		MG-RPT1 #1		MG-RPT1 #2	
<b>Bold</b>	Section:	[557]		[567]	
Option		OFF	ON	OFF	ON
[1]	Repeat Wireless 2-Way PGM 9 Signals	<input type="checkbox"/>	<input type="checkbox"/>	<input type="checkbox"/>	<input type="checkbox"/>
[2]	Repeat Wireless 2-Way PGM 10 Signals	<input type="checkbox"/>	<input type="checkbox"/>	<input type="checkbox"/>	<input type="checkbox"/>
[3]	Repeat Wireless 2-Way PGM 11 Signals	<input type="checkbox"/>	<input type="checkbox"/>	<input type="checkbox"/>	<input type="checkbox"/>
[4]	Repeat Wireless 2-Way PGM 12 Signals	<input type="checkbox"/>	<input type="checkbox"/>	<input type="checkbox"/>	<input type="checkbox"/>
[5]	Repeat Wireless 2-Way PGM 13 Signals	<input type="checkbox"/>	<input type="checkbox"/>	<input type="checkbox"/>	<input type="checkbox"/>
[6]	Repeat Wireless 2-Way PGM 14 Signals	<input type="checkbox"/>	<input type="checkbox"/>	<input type="checkbox"/>	<input type="checkbox"/>
[7]	Repeat Wireless 2-Way PGM 15 Signals	<input type="checkbox"/>	<input type="checkbox"/>	<input type="checkbox"/>	<input type="checkbox"/>
[8]	Repeat Wireless 2-Way PGM 16 Signals	<input type="checkbox"/>	<input type="checkbox"/>	<input type="checkbox"/>	<input type="checkbox"/>



Remote control signals are always repeated.

# Wireless Keypad Programming (MG32LRF)

## Automatic Wireless Keypad Assignment

After panel power-up, the control panel will open a 10 minute window for Automatic Assignment. Press and hold the [⏻] and [BYP] key for three seconds on the respective keypad. The keypad is assigned to the control panel. Up to 4 wireless keypads can be assigned within the ten minute window.

## Standard Wireless Keypad Assignment

Section	Wireless Keypad Serial Number
[570]	Keypad 1    ___/___/___/___/___/___
[571]	Keypad 2    ___/___/___/___/___/___
[572]	Keypad 3    ___/___/___/___/___/___
[573]	Keypad 4    ___/___/___/___/___/___



Enter serial number or press and hold the [⏻] and [BYP] key for three seconds.

## Wireless Keypad Signal Strength

Section	
[575]	Wireless Keypad 1 Signal Strength
[576]	Wireless Keypad 2 Signal Strength
[577]	Wireless Keypad 3 Signal Strength
[578]	Wireless Keypad 4 Signal Strength

Signal Strength Indicator	8 to 10 / 3 beeps = Best signal	5 to 7 / 2 beeps = Average signal	1 to 4 / 1 beep = Weak signal (Relocate)
---------------------------	---------------------------------	-----------------------------------	--



To view the wireless keypad's signal strength, press and hold the [⏻] and [BYP] key for three seconds.

## Wireless Keypad Options

[580]	Wireless Keypad Options	Bold = Default setting	
	Option	OFF	ON
[1]	Keypad 1 Supervision	<input type="checkbox"/> Disabled	<input checked="" type="checkbox"/> Enabled
[2]	Keypad 2 Supervision	<input type="checkbox"/> Disabled	<input checked="" type="checkbox"/> Enabled
[3]	Keypad 3 Supervision	<input type="checkbox"/> Disabled	<input checked="" type="checkbox"/> Enabled
[4]	Keypad 4 Supervision	<input type="checkbox"/> Disabled	<input checked="" type="checkbox"/> Enabled
[5]	N/A	N/A	N/A
[6]	N/A	N/A	N/A
[7]	N/A	N/A	N/A
[8]	Live Display Mode	<input type="checkbox"/> Disabled	<input checked="" type="checkbox"/> Enabled

# System Programming

## [700] General System Options Bold = Default setting

Option	OFF	ON
[1] Partitioning	<input type="checkbox"/> Disabled	<input type="checkbox"/> Enabled
[2] Battery charging (350mA or 700mA)	<input type="checkbox"/> 350mA	<input type="checkbox"/> 700mA
[3] Audible trouble warning (except AC failure)	<input type="checkbox"/> Disabled	<input type="checkbox"/> <b>Enabled</b>
[4] Audible trouble warning on AC failure	<input type="checkbox"/> <b>Disabled</b>	<input type="checkbox"/> Enabled
[5] RF jamming supervision	<input type="checkbox"/> Disabled	<input type="checkbox"/> <b>Enabled</b>
[6] Exit delay termination	<input type="checkbox"/> <b>Disabled</b>	<input type="checkbox"/> Enabled
[7] Tamper supervision on the bus module	<input type="checkbox"/> <b>Disabled</b>	<input type="checkbox"/> Enabled
[8] StayD Mode	<input type="checkbox"/> Disabled	<input type="checkbox"/> <b>Enabled</b>

## [701] General Code Options Bold = Default setting

Option	OFF	ON
[1] Access code length	<input type="checkbox"/> 6 digits	<input type="checkbox"/> <b>4 digits</b>
[2] Lock master code	<input type="checkbox"/> <b>Disabled</b>	<input type="checkbox"/> Enabled
[3] Confidential mode	<input type="checkbox"/> <b>Disabled</b>	<input type="checkbox"/> Enabled
[4] To exit confidential mode	<input type="checkbox"/> <b>Enter a code</b>	<input type="checkbox"/> Press a key
[5] Confidential mode timer	<input type="checkbox"/> <b>2 minutes</b>	<input type="checkbox"/> 5 seconds
[6] to [8] N/A	N/A	N/A

## [702] Panic Options Bold = Default setting

Option	OFF	ON
[1] Panic 1	<input type="checkbox"/> <b>Disabled</b>	<input type="checkbox"/> Enabled
[2] Panic 2	<input type="checkbox"/> <b>Disabled</b>	<input type="checkbox"/> Enabled
[3] Panic 3	<input type="checkbox"/> <b>Disabled</b>	<input type="checkbox"/> Enabled
[4] Panic 1: Silent or audible alarm	<input type="checkbox"/> <b>Silent</b>	<input type="checkbox"/> Audible
[5] Panic 2: Silent or audible alarm	<input type="checkbox"/> <b>Silent</b>	<input type="checkbox"/> Audible
[6] Panic 3: Silent or audible alarm	<input type="checkbox"/> <b>Silent</b>	<input type="checkbox"/> Audible
[7] & [8] N/A	N/A	N/A

## [703] Arming/Disarming Options 1 Bold = Default setting

Option	OFF	ON
[1] One-touch regular/force arming	<input type="checkbox"/> Disabled	<input type="checkbox"/> <b>Enabled</b>
[2] One-touch stay arming	<input type="checkbox"/> Disabled	<input type="checkbox"/> <b>Enabled</b>
[3] One-touch sleep arming	<input type="checkbox"/> Disabled	<input type="checkbox"/> <b>Enabled</b>
[4] One-touch bypass programming	<input type="checkbox"/> Disabled	<input type="checkbox"/> <b>Enabled</b>
[5] Restrict arming on battery failure	<input type="checkbox"/> <b>Disabled</b>	<input type="checkbox"/> Enabled
[6] Restrict arming on tamper failure (Zone + Bus Module + Wireless PGM)	<input type="checkbox"/> <b>Disabled</b>	<input type="checkbox"/> Enabled
[7] Restrict arming on wireless supervision trouble (Zone + Bus Module + Wireless PGM)	<input type="checkbox"/> <b>Disabled</b>	<input type="checkbox"/> Enabled
[8] N/A	N/A	N/A

**[704] Arming/Disarming Options 2 Bold = Default setting**

Option		OFF	ON
[1]	Regular arming switches to force arming	<input type="checkbox"/> Disabled	<input type="checkbox"/> <b>Enabled</b>
[2]	Stay arming switches to stay force arming	<input type="checkbox"/> Disabled	<input type="checkbox"/> <b>Enabled</b>
[3]	Sleep arming switches to sleep force arming	<input type="checkbox"/> Disabled	<input type="checkbox"/> <b>Enabled</b>
[4]	Bell squawk when arm/disarm with remote	<input type="checkbox"/> <b>Disabled</b>	<input type="checkbox"/> Enabled
[5]	Bell squawk when arm/disarm with a keypad	<input type="checkbox"/> <b>Disabled</b>	<input type="checkbox"/> Enabled
[6]	Beep on exit delay	<input type="checkbox"/> Disabled	<input type="checkbox"/> <b>Enabled</b>
[7]	No exit delay beeps and no bell squawk when stay/sleep arm	<input type="checkbox"/> Disabled	<input type="checkbox"/> <b>Enabled</b>
[8]	No exit delay when arm with a remote	<input type="checkbox"/> <b>Disabled</b>	<input type="checkbox"/> Enabled

**[705] General Zone Options 1 Bold = Default setting**

Option		OFF	ON
[1]	ATZ zone doubling	<input type="checkbox"/> <b>Disabled</b>	<input type="checkbox"/> Enabled
[2]	ATZ wiring options	<input type="checkbox"/> <b>Series</b>	<input type="checkbox"/> Parallel

**[3] & [4] Tamper Recognition**

[3]	[4]	RF Zone Tamper Recognition Options	Keypad Bus / RF Module Tamper Recognition Options*
OFF	OFF	Disabled	TROUBLE ONLY
OFF	ON	TROUBLE ONLY	TROUBLE ONLY
ON	OFF	When disarmed: TROUBLE ONLY When armed: Follow zone's alarm type	TROUBLE ONLY
ON	ON	When disarmed: AUDIBLE ALARM When armed: Follow zone's alarm type	AUDIBLE ALARM

\* Tamper recognition of keypad / bus module only if section [700] option [7] is enabled.

[5] Generate tamper on bypassed zone  No  **Yes**

**[6] & [7] Supervision Options**

[6]	[7]	RF Zone Supervision Options	Keypad Bus / RF Module Supervision Options
OFF	OFF	Disabled	Disabled
OFF	ON	TROUBLE ONLY	TROUBLE ONLY
ON	OFF	When disarmed: TROUBLE ONLY When armed: Follow zone's alarm type	TROUBLE ONLY
ON	ON	When disarmed: AUDIBLE ALARM When armed: Follow zone's alarm type	AUDIBLE ALARM

[8] Generate supervision on bypassed zone  No  **Yes**

**[706] General Zone Options 2 Bold = Default setting**

Option		OFF	ON
[1]	Check-in supervision time	<input type="checkbox"/> <b>24 hours</b>	<input type="checkbox"/> 80 minutes
[2]	EOL resistors	<input type="checkbox"/> <b>Disabled</b>	<input type="checkbox"/> Enabled
[3]	Zone Input 1 becomes a 2-wire smoke input	<input type="checkbox"/> <b>Disabled</b>	<input type="checkbox"/> Enabled
[4]	ZX8 ID A Input 1	<input type="checkbox"/> <b>Zone A</b>	<input type="checkbox"/> Tamper input
[5]	ZX8 ID B Input 1	<input type="checkbox"/> <b>Zone B</b>	<input type="checkbox"/> Tamper input
[6]	ZX8 ID C Input 1	<input type="checkbox"/> <b>Zone C</b>	<input type="checkbox"/> Tamper input
[4] to [8]	N/A	N/A	N/A

## System Timers

Section	Data	Description
[710]	___/___/___ (000 to 255) seconds	Entry delay 1 (default 045)
[711]	___/___/___ (000 to 255) seconds	Entry delay 2 (default 045)
[712]	___/___/___ (000 to 255)	Auto zone shutdown counter (Default 005)
[713]	___/___/___ (000 to 255) seconds	Intellizone delay (default 048)
[714]	___/___/___ (000 to 255) minutes	Recycle alarm delay (default 000)
[715]	___/___/___ (000 to 255)	Recycle alarm counter (default 000)
[716]	___/___/___ (000 to 255) minutes	Keypad lockout delay (default 000)
[717]	___/___/___ (000 to 255) attempt before locking	Keypad lockout counter (default 000)
[718]	___/___/___ (000 to 255) seconds	Remote panic disarm lock delay (default 000)
[719]	___/___/___ (000 to 255) days	Closing delinquency delay (default 000)
[720]	___/___/___ (000 to 255) seconds	For StayD: Flex-Instant delay (default 015)
[721]	___/___/___ (000 to 255) seconds	For StayD: Re-arm delay (default 005)



Refer to the **Installer Quick Menu** on page 3 for alternate entry/exit and bell cut-off timer programming.

## Daylight Savings Programming

[730]	General Zone Options 3	OFF	ON
	<b>Option</b>		
[1]	Daylight savings	<input type="checkbox"/> Disabled	<input type="checkbox"/> Enabled
[2]	N/A	N/A	N/A

Section	Data	Description
[731]	(00 to 99)	Country code

### Country Code List (Default = bold)

<b>00 = US, Canada, Mexico, St.Johns, Bahamas, Turks and Caicos</b>	09 = Lord Howe Island- Tasmania
01 = Cuba	10 = New Zealand, Chatham
02 = Brazil	11 = Tonga
03 = Chile	12 = Iraq and Syria
04 = Falklands	13 = N/A
05 = Paraguay	14 = Lebanon, Kirgizstan
06 = European Union, UK, and Greenland	15 = Palestine
07 = Russia and most states of the former USSR	16 = Egypt
08 = Australia- South Australia, Victoria, Australian Capital Territory, New South Wales	17 = Namibia
	18 = USA, Canada 2007

# Partition Programming

[741]	Partition 1 Options		Bold = Default setting												
	<b>Option</b>		<b>OFF</b> <b>ON</b>												
[1]	Auto-arm on time	<input type="checkbox"/> Disabled	<input type="checkbox"/> Enabled												
[2]	Auto-arm on no movement	<input type="checkbox"/> Disabled	<input type="checkbox"/> Enabled												
	Auto-arm arming mode	<input type="checkbox"/> See Table	<input type="checkbox"/> See Table												
[3]& [4]	<table border="1"> <thead> <tr> <th>[3]</th> <th>[4]</th> <th></th> </tr> </thead> <tbody> <tr> <td>OFF</td> <td>OFF</td> <td>Regular</td> </tr> <tr> <td>OFF</td> <td>ON</td> <td>Sleep</td> </tr> <tr> <td>ON</td> <td>OFF</td> <td>Stay</td> </tr> </tbody> </table>	[3]	[4]		OFF	OFF	Regular	OFF	ON	Sleep	ON	OFF	Stay		
	[3]	[4]													
	OFF	OFF	Regular												
OFF	ON	Sleep													
ON	OFF	Stay													
[5]	Switch to stay arming if no zone entry delay is opened	<input type="checkbox"/> Disabled	<input type="checkbox"/> Enabled												
[6]	Follow zones become entry delay 2 when delay zone is bypassed	<input type="checkbox"/> Disabled	<input type="checkbox"/> Enabled												
[7]& [8]	N/A	N/A	N/A												

[742]	Partition 2 Options		Bold = Default setting												
	<b>Option</b>		<b>OFF</b> <b>ON</b>												
[1]	Auto-arm on time	<input type="checkbox"/> Disabled	<input type="checkbox"/> Enabled												
[2]	Auto-arm on no movement	<input type="checkbox"/> Disabled	<input type="checkbox"/> Enabled												
	Auto-arm arming mode	<input type="checkbox"/> See Table	<input type="checkbox"/> See Table												
[3]& [4]	<table border="1"> <thead> <tr> <th>[3]</th> <th>[4]</th> <th></th> </tr> </thead> <tbody> <tr> <td>OFF</td> <td>OFF</td> <td>Regular</td> </tr> <tr> <td>OFF</td> <td>ON</td> <td>Sleep</td> </tr> <tr> <td>ON</td> <td>OFF</td> <td>Stay</td> </tr> </tbody> </table>	[3]	[4]		OFF	OFF	Regular	OFF	ON	Sleep	ON	OFF	Stay		
	[3]	[4]													
	OFF	OFF	Regular												
OFF	ON	Sleep													
ON	OFF	Stay													
[5]	Switch to stay arming if no entry delay is opened	<input type="checkbox"/> Disabled	<input type="checkbox"/> Enabled												
[6]	Follow zones become entry delay 2 when delay zone is bypassed	<input type="checkbox"/> Disabled	<input type="checkbox"/> Enabled												
[7]& [8]	N/A	N/A	N/A												

## Partition Timers

Section	Data	Description
[745]	___/___/___	(000 to 255) seconds Partition 1 exit delay (default 060)
[746]	___/___/___	(000 to 255) seconds Partition 2 exit delay (default 060)
[747]	___/___/___	(000 to 255) minutes Partition 1 bell cut-off (default 004)
[748]	___/___/___	(000 to 255) minutes Partition 2 bell cut-off (default 004)
[749]	___/___/___	(000 to 255) x 15 minutes Partition 1 no movement (default 000)
[750]	___/___/___	(000 to 255) x 15 minutes Partition 2 no movement (default 000)

Section	Data	Description
[761]	___/___:___/___	HH: MM Auto-arm on time Partition 1 (default 00:00)
[762]	___/___:___/___	HH: MM Auto-arm on time Partition 2 (default 00:00)

# Communication Programming

## [800] Dialer Options Bold = Default setting

	<b>Option</b>	<b>OFF</b> <input type="checkbox"/> See Table	<b>ON</b> <input type="checkbox"/> See Table																	
	<table border="1" style="margin: auto;"> <thead> <tr> <th colspan="3">Telephone Line Monitoring (TLM) Options</th> </tr> <tr> <th>[1]</th> <th>[2]</th> <th></th> </tr> </thead> <tbody> <tr> <td>OFF</td> <td>OFF</td> <td>Disabled</td> </tr> <tr> <td>OFF</td> <td>ON</td> <td>When disarmed: Trouble only When armed: Trouble only</td> </tr> <tr> <td>ON</td> <td>OFF</td> <td>When disarmed: Trouble only When armed: Audible alarm</td> </tr> <tr> <td>ON</td> <td>ON</td> <td>Silent alarms become Audible alarm</td> </tr> </tbody> </table>	Telephone Line Monitoring (TLM) Options			[1]	[2]		OFF	OFF	Disabled	OFF	ON	When disarmed: Trouble only When armed: Trouble only	ON	OFF	When disarmed: Trouble only When armed: Audible alarm	ON	ON	Silent alarms become Audible alarm	
Telephone Line Monitoring (TLM) Options																				
[1]	[2]																			
OFF	OFF	Disabled																		
OFF	ON	When disarmed: Trouble only When armed: Trouble only																		
ON	OFF	When disarmed: Trouble only When armed: Audible alarm																		
ON	ON	Silent alarms become Audible alarm																		
[1] & [2]																				
[3]	Switch to pulse on 5 <sup>th</sup> attempt	<input type="checkbox"/> <b>Disabled</b>	<input type="checkbox"/> Enabled																	
[4]	Alternate dial	<input type="checkbox"/> <b>Disabled</b>	<input type="checkbox"/> Enabled																	
[5]	Force dial (must be enabled to comply with TBR-21)	<input type="checkbox"/> Disabled	<input type="checkbox"/> <b>Enabled</b>																	
[6]	DTMF dialing	<input type="checkbox"/> Disabled	<input type="checkbox"/> <b>Enabled</b>																	
[7]	Pulse ratio	<input type="checkbox"/> 1:2	<input type="checkbox"/> <b>1:1.5</b>																	
[8]	N/A	N/A	N/A																	

## [801] Dialer Options Bold = Default setting

	<b>Option</b>	<b>OFF</b>	<b>ON</b>
[1]	Report system disarming	<input type="checkbox"/> Always	<input type="checkbox"/> <b>After alarm</b>
[2]	Report zone restore	<input type="checkbox"/> <b>Bell cutoff</b>	<input type="checkbox"/> Zone closure
[3] to [8]	N/A	N/A	N/A

## [802] Event Call Direction Options 1 Bold = Default setting

	<b>Option</b>	<b>OFF</b>	<b>ON</b>
[1]	Call tel. #1 for arm/disarm reporting codes	<input type="checkbox"/> Disabled	<input type="checkbox"/> <b>Enabled</b>
[2]	Call tel. #2 for arm/disarm reporting codes	<input type="checkbox"/> Disabled	<input type="checkbox"/> <b>Enabled</b>
[3]	Call pager for arm/disarm reporting codes	<input type="checkbox"/> <b>Disabled</b>	<input type="checkbox"/> Enabled
[4]	N/A	N/A	N/A
[5]	Call tel. #1 for alarm/restore reporting codes	<input type="checkbox"/> Disabled	<input type="checkbox"/> <b>Enabled</b>
[6]	Call tel. #2 for alarm/restore reporting codes	<input type="checkbox"/> Disabled	<input type="checkbox"/> <b>Enabled</b>
[7]	Call pager for alarm/restore reporting codes	<input type="checkbox"/> Disabled	<input type="checkbox"/> <b>Enabled</b>
[8]	N/A	N/A	N/A

## [803] Event Call Direction Options 2 Bold = Default setting

	<b>Option</b>	<b>OFF</b>	<b>ON</b>
[1]	Call tel. #1 for tamper/restore reporting codes	<input type="checkbox"/> Disabled	<input type="checkbox"/> <b>Enabled</b>
[2]	Call tel. #2 for tamper/restore reporting codes	<input type="checkbox"/> Disabled	<input type="checkbox"/> <b>Enabled</b>
[3]	Call pager for tamper/restore reporting codes	<input type="checkbox"/> <b>Disabled</b>	<input type="checkbox"/> Enabled
[4]	N/A	N/A	N/A
[5]	Call tel. #1 for trouble/restore reporting codes	<input type="checkbox"/> Disabled	<input type="checkbox"/> <b>Enabled</b>
[6]	Call tel. #2 for trouble/restore reporting codes	<input type="checkbox"/> Disabled	<input type="checkbox"/> <b>Enabled</b>
[7]	Call pager for trouble/restore reporting codes	<input type="checkbox"/> <b>Disabled</b>	<input type="checkbox"/> Enabled
[8]	N/A	N/A	N/A





## Communication Timers

Section	Data	Description
[830]	___/___/___	(000 to 255) x 2 sec. TLM fail delay (default 016)
[831]	___/___/___	(000 to 255) max 32 Maximum dialing attempts (default 008)
[832]	___/___/___	(000 to 255) sec. (max 127) Delay between attempts (default 020)
[833]	___/___/___	(000 to 255) seconds Delay alarm transmission (default 000)
[834]	___/___/___	(000 to 255) sec. (max 127) Pager reporting delay (default 020)
[835]	___/___/___	(000 to 255) max 10 Pager reporting message repetition (default 003)
[836]	___/___/___	(000 to 255) sec. (max 127) Personal reporting delay (default 005)
[837]	___/___/___	(000 to 255) max 10 Personal reporting message repetition (default 003)
[838]	___/___/___	(000 to 255) seconds Recent closing delay (default 000)
[839]	___/___/___	(000 to 255) minutes Power failure report delay (default 015)
[840]	___/___/___	(000 to 255) days Auto test report (default 000)

Section	Data	Description
[850]	___/___:___/___	HH: MM Auto test report time of day (default 00:00)

## Special Arming Report Codes (Default = FF)

Section	Data	Description	Section	Data	Description
[860]	___/___	Auto-arming	[861]	___/___	Quick arming
	___/___	Late to close		___/___	Arming via PC
	___/___	No movement		___/___	N/A
	___/___	Partial arming		___/___	N/A

## Special Disarming Report Codes (Default = FF)

Section	Data	Description
[862]	___/___	Cancel auto-arm
	___/___	Disarming via PC
	___/___	Cancel alarm with user or WinLoad
	___/___	Cancel paramedic

## Special Alarm Report Codes (Default = FF)

Section	Data	Description	Section	Data	Description
[863]	___/___	Emergency panic	[864]	___/___	Zone shutdown
	___/___	Auxiliary panic		___/___	Duress
	___/___	Fire panic		___/___	Keypad lockout
	___/___	Recent closing		___/___	Paramedic alarm



Refer to *Decimal and Hexadecimal Values* on page 41.

## System Trouble Report Codes (Default = FF)

Section			Section		
[865]	___/___	N/A	[868]	___/___	Module power fail
	___/___	AC failure		___/___	Module low/no battery
	___/___	Battery failure		___/___	Wireless zone low battery
	___/___	Auxiliary supply		___/___	Wireless zone supervision lost
[866]	___/___	Bell output overload	[869]	___/___	Wireless module supervision lost
	___/___	Bell output disconnect		___/___	Wireless module tamper
	___/___	Timer loss		___/___	N/A
	___/___	Fire loop trouble		___/___	Wireless module low battery
[867]	___/___	Fail to communicate			
	___/___	RF interference			
	___/___	Module lost			
	___/___	Module tamper			

## System Trouble Restore Report Code (Default = FF)

Section	Data	Description	Section	Data	Description
[870]	___/___	TLM	[873]	___/___	Module power fail
	___/___	AC failure		___/___	Module low/no battery
	___/___	Battery failure		___/___	Wireless zone low battery
	___/___	Auxiliary supply		___/___	Wireless zone supervision lost
[871]	___/___	Bell output overload	[874]	___/___	Wireless module supervision lost
	___/___	Bell output disconnect		___/___	Wireless module tamper
	___/___	Timer loss		___/___	N/A
	___/___	Fire loop trouble		___/___	N/A
[872]	___/___	Fail to communicate			
	___/___	RF interference			
	___/___	Module lost			
	___/___	Module tamper			

## System Special Report Code (Default = FF)

Section	Data	Description	Section	Data	Description
[875]	___/___	Cold start	[876]	___/___	Installer in
	___/___	Test report		___/___	Installer out
	___/___	N/A		___/___	Closing Delinquency
	___/___	WinLoad out		___/___	N/A



Refer to *Decimal and Hexadecimal Values* on page 41.



# Appendix 1: Ademco Contact ID Report Codes

CID#	Reporting Code	Programming Value
<b>Medical Alarms - 100</b>		
100	Medical alarm	01
101	Pendant transmitter	02
102	Fail to report in	03
<b>Fire Alarms - 110</b>		
110	Fire alarm	04
111	Smoke	05
112	Combustion	06
113	Water flow	07
114	Heat	08
115	Pull station	09
116	Duct	0A
117	Flame	0B
118	Near alarm	0C
<b>Panic Alarms - 120</b>		
120	Panic Alarm	0D
121	Duress	0E
122	Silent	0F
123	Audible	10
124	Duress - Access grated	11
125	Duress - Egress granted	12
<b>Burglar Alarms - 130</b>		
130	Burglary	13
131	Perimeter	14
132	Interior	15
133	24-hour	16
134	Entry/Exit	17
135	Day/Night	18
136	Outdoor	19
137	Tamper	1A
138	Near alarm	1B
139	Intrusion verified	1C
<b>General Alarms - 140</b>		
140	General alarm	1D
141	Polling loop open	1E
142	Polling loop short	1F
143	Expansion module failure	20
144	Sensor tamper	21
145	Expansion module tamper	22
146	Silent burglary	23
147	Sensor supervision failure	24
<b>24-hour Non-burglary - 150 and 160</b>		
150	24-hour non-burglary	25

CID#	Reporting Code	Programming Value
151	Gas detected	26
152	Refrigeration	27
153	Loss of heat	28
154	Water leakage	29
155	Foil break	2A
156	Day trouble	2B
157	Low bottled gas level	2C
158	High temperature	2D
159	Low temperature	2E
161	Loss of air flow	2F
162	Carbon monoxide detected	30
163	Tank level	31
<b>Fire Supervisory - 200 and 210</b>		
200	Fire supervisory	32
201	Low water pressure	33
202	Low CO <sub>2</sub>	34
203	Gate valve sensor	35
204	Low water level	36
205	Pump activated	37
206	Pump failure	38
<b>System Troubles - 300 and 310</b>		
300	System trouble	39
301	AC loss	3A
302	Low system battery	3B
303	RAM checksum bad	3C
304	ROM checksum	3D
305	System reset	3E
306	Panel program changed	3F
307	Self-test failure	40
308	System shutdown	41
309	Battery test failure	42
310	Ground fault	43
311	Battery missing/dead	44
312	Power supply over current limit	45
313	Engineer reset	46
<b>Sounder/Relay Troubles - 320</b>		
320	Sounder/relay	47
321	Bell 1	48
322	Bell 2	49
323	Alarm relay	4A
324	Trouble relay	4B
325	Reversing relay	4C
326	Notification appliance chk. #3	4D

CID#	Reporting Code	Programming Value
327	Notification appliance chk. #4	4E
<b>System Peripheral Troubles - 330 and 340</b>		
330	System peripheral	4F
331	Polling loop open	50
332	Polling loop short	51
333	Expansion module failure	52
334	Repeater failure	53
335	Local printer paper out	54
336	Local printer failure	55
337	Exp. module DC loss	56
338	Exp. module low battery	57
339	Exp. module reset	58
341	Exp. module tamper	59
342	Exp. module AC loss	5A
343	Exp. module self-test fail	5B
344	RF receiver jam detect	5C
<b>Communication Troubles - 350 and 360</b>		
350	Communication	5D
351	Telco 1 fault	5E
352	Telco 2 fault	5F
353	Long range radio	60
354	Fail to communicate	61
355	Loss of radio supervision	62
356	Loss of central polling	63
357	Long range radio VSWR prob.	64
<b>Protection Loop Troubles - 370</b>		
370	Protection loop	65
371	Protection loop open	66
372	Protection loop short	67
373	Fire trouble	68
374	Exit error alarm	69
375	Panic zone trouble	6A
376	Hold-up zone trouble	6B
377	Swinger trouble	6C
378	Cross-zone trouble	6D
<b>Sensor Troubles - 380 and 390</b>		
380	Sensor trouble	6E
381	Loss of supervision - RF	6F
382	Loss of supervision - RPM	70
383	Sensor tamper	71
384	RF transmitter low battery	72
385	Smoke detector Hi sensitivity	73
386	Smoke detector Low sensitivity	74

CID#	Reporting Code	Programming Value
387	Intrusion detector Hi sensitivity	75
388	Intrusion detector Low sensitivity	76
389	Sensor self-test failure	77
391	Sensor watch trouble	78
392	Drift compensation error	79
393	Maintenance alert	7A
<b>Open/Close - 400</b>		
400	Open/Close	7B
401	Open/Close by user	7C
402	Group open/close	7D
403	Automatic open/close	7E
406	Cancel	7F
407	Remote arm/disarm	80
408	Quick arm	81
409	Keyswitch open/close	82
<b>Remote Access - 410</b>		
411	Call back request made	83
412	Success - download access	84
413	Unsuccessful access	85
414	System shutdown	86
415	Dialer shutdown	87
416	Successful upload	88
<b>Access Control - 420 and 430</b>		
421	Access denied	89
422	Access report by user	8A
423	Forced access	8B
424	Egress denied	8C
425	Egress granted	8D
426	Access door propped open	8E
427	Access point door status monitor trouble	8F
428	Access point request to exit	90
429	Access program mode entry	91
430	Access program mode exit	92
431	Access threat level change	93
432	Access relay/trigger fail	94
433	Access RTE shunt	95
434	Access DSM shunt	96
<b>Arming - 440 and 450</b>		
441	Armed Stay	97
442	Keyswitch armed Stay	98
450	Exception open/close	99

CID#	Reporting Code	Programming Value
451	Early open/close	9A
452	Late open/close	9B
453	Failed to open	9C
454	Failed to close	9D
455	Auto-arm failed	9E
456	Partial arm	9F
457	Exit error (user)	A0
458	User on premises	A1
459	Recent close	A2
<b>System - 460</b>		
461	Wrong code entry	A3
462	Legal code entry	A4
463	Re-arm after alarm	A5
464	Auto-arm time extended	A6
465	Panic alarm reset	A7
466	Service ON/OFF premises	A8
<b>Sounder Relay Disabled - 520</b>		
520	Sounder/Relay disabled	A9
521	Bell 1 disabled	AA
522	Bell 2 disabled	AB
523	Alarm relay disabled	AC
524	Trouble relay disabled	AD
525	Reversing relay disabled	AE
526	Notification appliance chk. #3 disabled	AF
527	Notification appliance chk. #4 disabled	B0
<b>Modules - 530</b>		
531	Module added	B1
532	Module removed	B2
<b>Communication Disables - 550 and 560</b>		
551	Dialer disabled	B3
552	Radio transmitter disabled	B4
<b>Bypasses - 570</b>		
570	Zone bypass	B5
571	Fire bypass	B6
572	24Hr. zone bypass	B7
573	Burglary bypass	B8
574	Group bypass	B9
575	Swinger bypass	BA
576	Access zone shunt	BB
577	Access point bypass	BC
<b>Test/Misc. - 600</b>		
601	Manual trigger test	BD
602	Periodic test report	BE

CID#	Reporting Code	Programming Value
603	Periodic RF transmission	BF
604	Fire test	C0
605	Status report to follow	C1
606	Listen-in to follow	C2
607	Walk test mode	C3
608	Periodic test - system trouble present	C4
609	Video transmitter active	C5
611	Point test OK	C6
612	Point not tested	C7
613	Intrusion zone walk tested	C8
614	Fire zone walk tested	C9
615	Panic zone walk tested	CA
616	Service request	CB
621	Event log reset	CC
622	Event log 50% full	CD
623	Event log 90% full	CE
624	Event log overflow	CF
625	Time/Date reset	D0
626	Time/Date inaccurate	D1
627	Program mode entry	D2
628	Program mode exit	D3
629	32-hour event log marker	D4
630	Schedule change	D5
631	Exception schedule change	D6
632	Access schedule change	D7
654	System inactivity	D8

## Appendix 2: Automatic Report Code List

System Event	Default Contact ID Report Code	Default SIA Report Code
Arming with User Code (##)	3 4A1 - Close by user	CL - Closing report
Auto arming	3 4A3 - Automatic close	CA - Automatic closing
Late to close	3 452 - Late to close	OT - Late to close
No movement	3 452 - Late to close	NA - No activity
Partial arming	1 456 - Group bypass	CG - Close area
Quick arming	3 4A8 - Quick arm	CL - Closing report
Arm with PC software	3 4A7 - Remote arm/disarm	CQ - Remote arming
Disarm with User Code (##)	1 4A1 - Open by user	OP - Opening report
Disarm after alarm* with User Code (##)	1 4A1 - Open by user	OP - Opening report
Cancel alarm** with User Code (##)	1 4A6 - Cancel by user	OR - Disarm from alarm
Auto-arming cancellation	1 464 - Deferred open/close	CE - Closing extend
Disarm with PC software	1 4A7 - Remote arm/disarm	OQ - Remote disarming
Disarm after an alarm with PC software	1 4A7 - Remote arm/disarm	OR - Disarm from alarm
Cancel alarm with PC software	1 4A6 - Cancel by user	OR - Disarm from alarm
Cancel paramedic alarm	1 4A6 - Cancel by user	MH - Medical alarm restore
Zone bypassed (##)	1 57A - Zone bypass	UB - Untyped zone bypass
Zone alarm (##)	1 13A - Burglary alarm	BA - Burglary alarm
Fire alarm (##)	1 11A - Fire alarm	FA - Fire alarm
Zone alarm restore (##)	3 13A - Burglary alarm restore	BH - Burglary alarm restore
Fire alarm restore (##)	3 11A - Fire alarm restore	FH - Fire alarm restore
Panic 1 - emergency	1 12A - Panic alarm	PA - Panic alarm
Panic 2 - medical	1 1AA - Medical alarm	MA - Medical alarm
Panic 3 - fire	1 115 - Pull station	FA - Fire alarm
Recent closing	3 459 - Open/Close	CR - Recent closing
Global zone shutdown	1 575 - Group bypass	CG - Close area
Duress alarm	1 121 - Duress	HA - Hold-up alarm
Keypad lockout	1 421 - Access denied	JA - User code tamper
Zone shutdown (##)	1 57A - Zone bypass	UB - Untyped zone bypass
Zone tampered (##)	1 144 - Sensor tamper	TA - Tamper alarm
Zone tamper restore (##)	3 144 - Sensor tamper restore	TR - Tamper restoral
AC failure	1 3A1 - AC loss	AT - AC trouble
Battery failure	1 3A9 - Battery test failure	YT - System battery trouble
Auxiliary supply trouble	1 3AA - System trouble	YP - Power supply trouble
Bell output current limit	1 321 - Bell 1	YA - Bell fault
Bell absent	1 321 - Bell 1	YA - Bell fault
Clock lost	1 626 - Time/date inaccurate	JT - Time changed
Fire loop trouble	1 373 - Fire trouble	FT - Fire trouble
Communication fail	1 354 - Communication fail	YC - Fail to communicate
RF interference	1 344 - RF receiver jam detection	XQ - RF Interference
TLM trouble restore	3 351 - Telco 1 fault restore	LR - Phone line restoral
AC failure restore	3 3A1 - AC loss restore	AR - AC restoral
Battery failure restore	3 3A9 - Battery test restore	YR - System battery restoral

\* An armed system is or was in alarm and was disarmed by a user.

\*\* A disarmed system is or was in alarm (e.g. 24Hr. zone) and was disarmed by a user.

System Event	Default Contact ID Report Code	Default SIA Report Code
Auxiliary supply trouble restore	3 3AA - System trouble restore	YQ - Power supply restored
Bell output current limit restore	3 321 - Bell 1 restore	YH - Bell restored
Bell absent restore	3 321 - Bell 1 restore	YH - Bell restored
Clock programmed	3 625 - Time/date reset	JT - Time changed
Fire loop trouble restore	3 373 - Fire trouble restore	FJ - Fire trouble restore
Fail to communicate with monitoring station	3 354 - Fail to communicate	YK - Communication fails
RF interference	3 344 - RF receiver jam detection	XH - RF Interference Restoral
Combus fault	1 333 - Expansion module failure	ET - Expansion trouble
Module tamper	1 341 - Expansion module tamper	TA - Tamper alarm
Bus fault restore	3 333 - Expansion module failure restore	ER - Expansion restoral
Module tamper restore	3 341 - Expansion module tamper restore	TR - Tamper restoral
Cold start	1 3A8 - System shutdown	RR - Power up
Test report engaged	1 6A2 - Periodic test report	TX - Test report
PC software communication finished	1 412 - Successful - download access	RS - Remote program success
Installer on site	1 627 - Program mode entry	LB - Local program
Installer programming finished	1 628 - Program mode exit	LS - Local program success
Maintenance in	1 627 - Program mode entry	LB - Local program
Maintenance out	1 628 - Program mode exit	LS - Local program success
Closing delinquency	1 654 - System inactivity	CD - System inactivity
Module AC fail	1 342 - AC failure on module	AT - Module AC fail
Module AC fail restore	3 342 - AC restored on module	AR - Module AC fail restore
Module battery fail	1 338 - Battery failure on module	YT - Module battery fail
Module battery fail restore	3 338 - Battery failure on module	YR - Module battery fail restore
RF Module low battery	1 384 - RF transmitter low battery	XT - Transmitter battery trouble
RF Module battery restore	3 384 - RF transmitter battery restore	XR - Transmitter battery restoral
RF Module supervision trouble	1 381 - Loss of supervision - RF	US - Untype zone supervision
RF Module supervision restore	3 381 - Supervision restore - RF	UR - Untyped zone restoral
RF Module supervision lost	1 381 - Loss of supervision- RF	US - Untyped Zone Supervisory
RF Module supervision restore	3 381 - Loss of supervision- RF restore	UR - Untyped Zone Restoral
RF Module tamper	1 145 - Expansion module tamper	ES - Expansion Device Tamper
RF Module tamper restore	3 145 - Expansion module tamper restore	EJ - Expansion Device Restore
Paramedic alarm	1 1AA - Medical	MA - Medical Alarm
Zone forced	1 57A - Zone forced	XW - Zone forced
Zone included	3 57A - Zone included	UU - Zone included



# Appendix 3: Data Entry & Display

To access the Data Display Mode, press the **[ENTER]** key after entering a section and before entering any data. The four LEDs as indicated below will begin to flash indicating that you are in the Data Display Mode.



Each time the **[ENTER]** key is pressed, the keypad will display the next digit in the current section and will continue through all the following sections one digit at a time without changing the programmed values. Not available for sections using the Multiple Feature Select Method. Press the **[CLEAR]** key at any time to exit the Data Display Mode.

There are two methods that can be used to enter data when in programming mode: Single Digit Data Entry and Feature Select Programming methods.

## Single Digit Data Entry Method

After entering programming mode, some sections will require that you enter decimal values from 000 to 255. Other sections will require that you enter hexadecimal values from 0 to F. The required data will be clearly indicated in this manual. When entering the final digit in a section, the panel will automatically save and advance to the next section. Refer to *Decimal and Hexadecimal Values* on page 41 to see the keys and their equivalent decimal and/or hexadecimal value.

## Feature Select Programming Method

After entering certain sections, eight options will be displayed where each option from **[1]** to **[8]** represents a specific feature. Press the key corresponding to the desired option. This means the option is ON. Press the key again to remove the digit, thereby, turning OFF the option. Press the **[CLEAR]** key to set all eight options to OFF. When the options are set, press the **[ENTER]** key to save and advance to the next section.

## Decimal and Hexadecimal Values

Value or Action	What Do I Press?	What Do I See?	
		32-zone LED	10-zone LED
Value 0 / Replace Current Digit with 0	<b>[SLEEP]</b>	Erase digit and remain in section	Erase digit and remain in section
Values 1 to 9	<b>[1] to [9]</b>	Zone 1 to 9	Keys 1 to 9
A (hex only)	<b>[0]</b>	Zone 10	Key 0(10)
B (hex only)	<b>[OFF]</b>	Zone 11	OFF
C (hex only)	<b>[BYP]</b>	Zone 12	BYP
D (hex only)	<b>[MEM]</b>	Zone 13	MEM
E (hex only)	<b>[TBL]</b>	Zone 14	TBL
F (hex only)	<b>[⏻]</b>	Zone 15	<b>[⏻]</b>
Exit Without Saving	<b>[CLEAR]</b>	ARM & STAY LED flash	ARM & STAY LED flash
Save Data (hex only)	<b>[ENTER]</b>	Advances to the next section	Advances to the next section

# Hardware Connections

## Single Zone Inputs

**N.C. Contacts, No EOL**

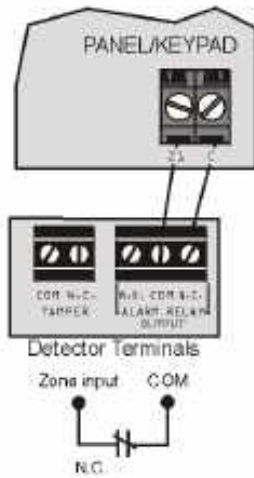

**N.C., With EOL  
UL/ULC Configuration**

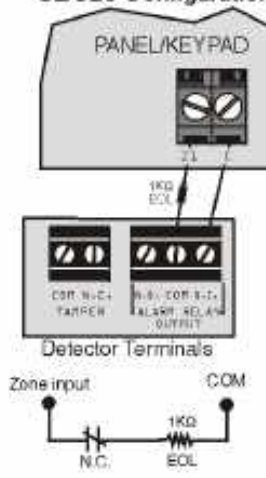

**N.O., With EOL  
UL/ULC Configuration**

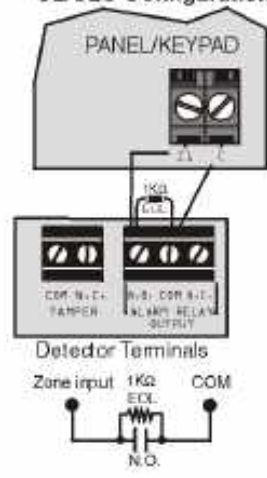

**N.C. Contacts, No EOL,  
With Tamper Recognition**

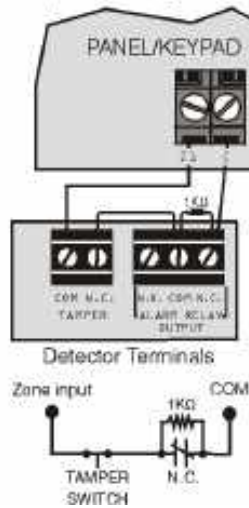

**N.C., With EOL, With Tamper &  
Wire Fault Recognition (UL/ULC)**

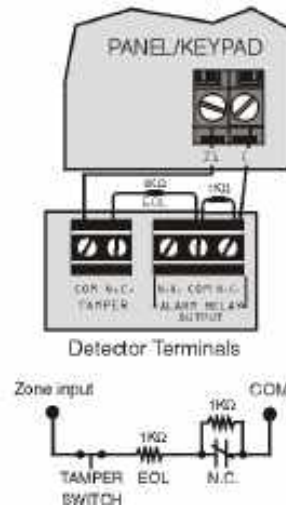

# Advanced Technology Zone (ATZ) Connections

N.C. Contacts, No EOL

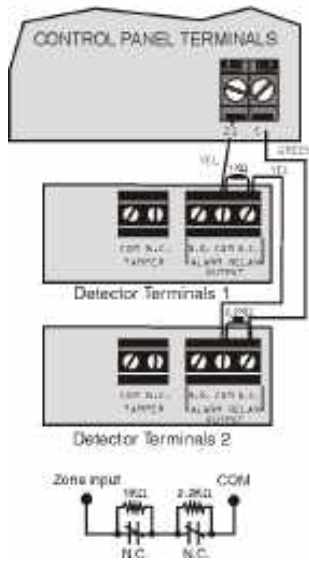

N.C. Contacts, No EOL, with Tamper Recognition

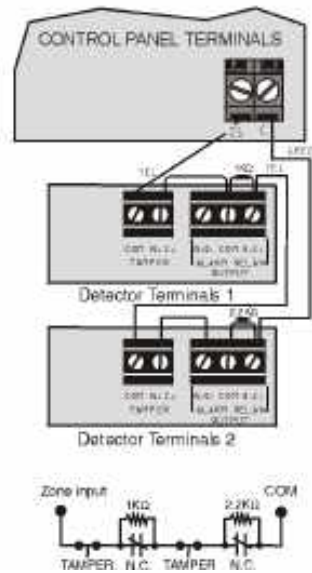

N.C. Contacts, with EOL, with Tamper and Wire Fault Recognition (UL/cUL)

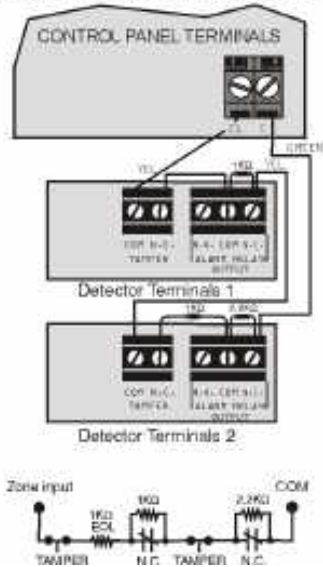

Parallel Wiring

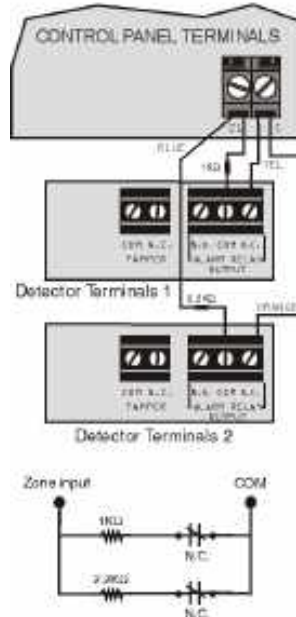

## Connecting Fire Circuits and PGMs



For 4-wire installation:  
Program the Activation Event so that the smoke detectors can be reset by pressing the **[CLEAR] + [ENTER]** keys for three seconds. See Event Group # 6 on page 15. For 2-wire installation: Press **[CLEAR] + [ENTER]** to automatically reset smoke.



**All 4-wire smoke detectors must be connected using the daisy chain configuration.**



**Each control panel supports a maximum of five 2-wire smoke detectors.**

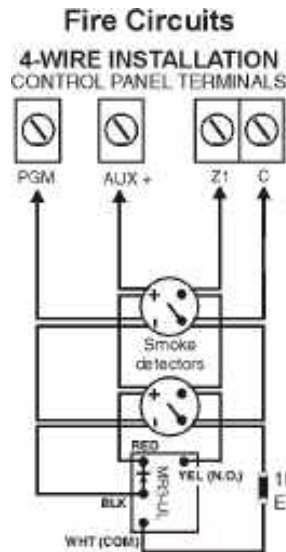

### 2-WIRE INSTALLATION CONTROL PANEL TERMINALS

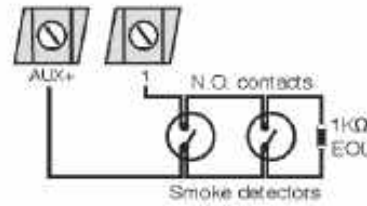

### PGM

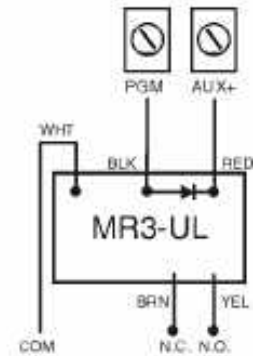

## Alarm Relay and PGM Connections

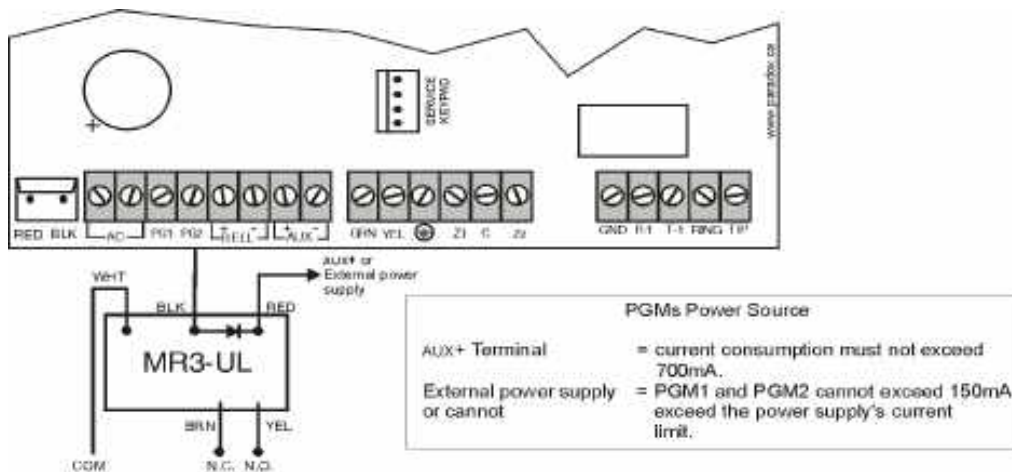

## AC Power & Backup Battery Connections

Transformer Requirements Table

Transformer:	16VAC <b>20VA*</b> (Amseco XP-1620) 16.5VAC <b>40VA</b> (Universal UB1640W) *not verified by UL
DC Power Supply rated at:	MG5000/MG5050 = 1.0A SP5500/SP6000/SP7000 = 1.4A
Auxiliary Supply can provide a maximum of:	typ: 600mA max: 700mA UL installations: typ. 200mA
Acceptable Battery Charge Currents (section [127] option [5])	350mA/700mA

Rechargeable Battery  
UL/ULC - 12Vdc / 4Ah or 7Ah

Partial view of control panel

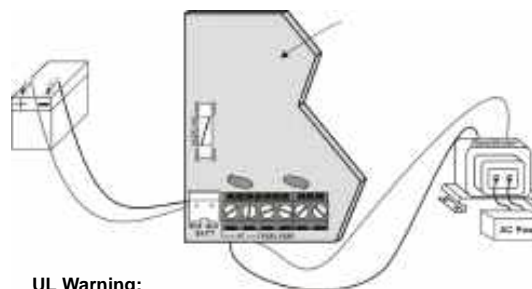

**Improper connection of the transformer may result in damage to the system.**

**UL Warning:**  
A 12Vdc / 7Ah battery is required to comply with UL fire requirements.

**Caution:**  
Disconnect battery before replacing the fuse.

## MG5000 8x10" Metal Box Installation

--- = PCB Position

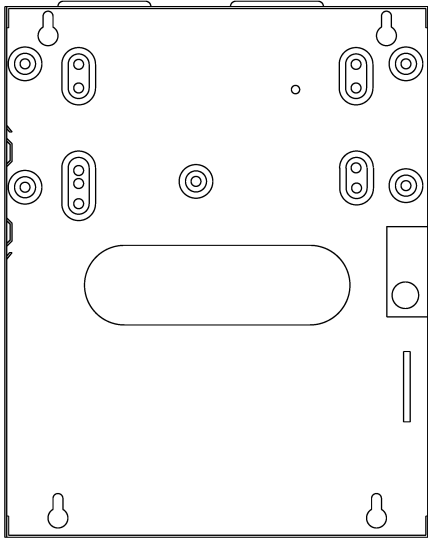

Old Metal Box

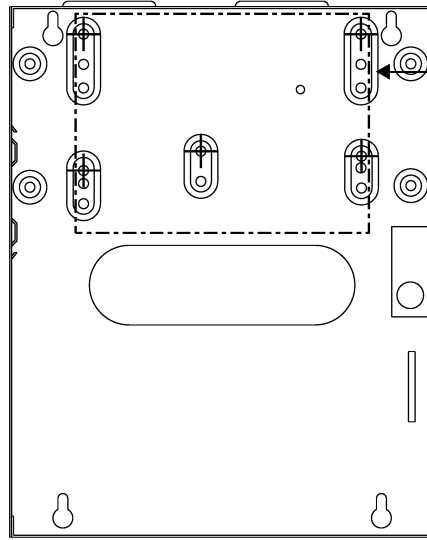

MG5000 Compatible Metal Box

If you need specific dimensions, contact Paradox Distributor Support.

## MG5000 11x11" Metal Box Installation

--- = PCB Position

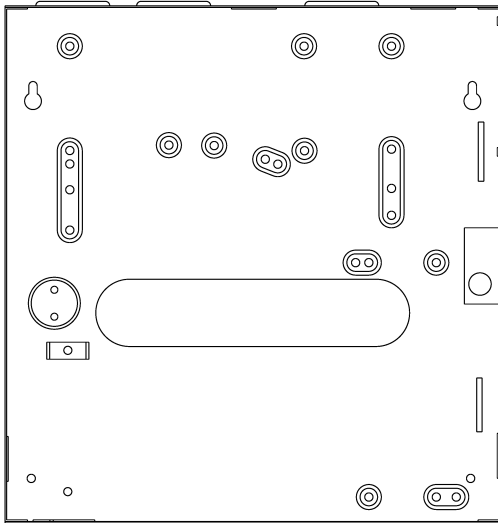

Old Metal Box

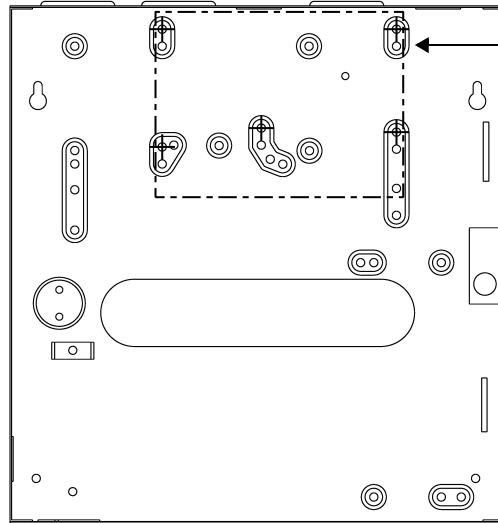

MG5000 Compatible Metal Box

If you need specific dimensions, contact Paradox Distributor Support.

## MG5050 11x11" Metal Box Installation

--- = PCB Position

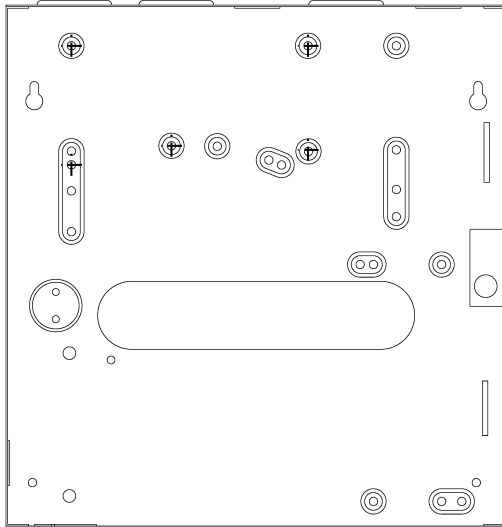

Old Metal Box

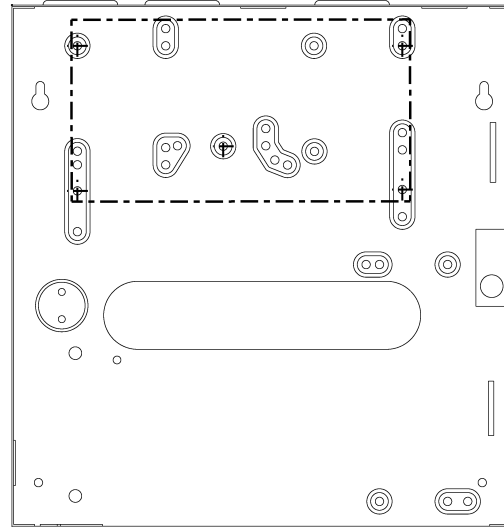

MG5050 Compatible Metal Box

If you need specific dimensions, contact Paradox Distributor Support.

## SP5500 8x11" Metal Box Installation

--- = PCB Position

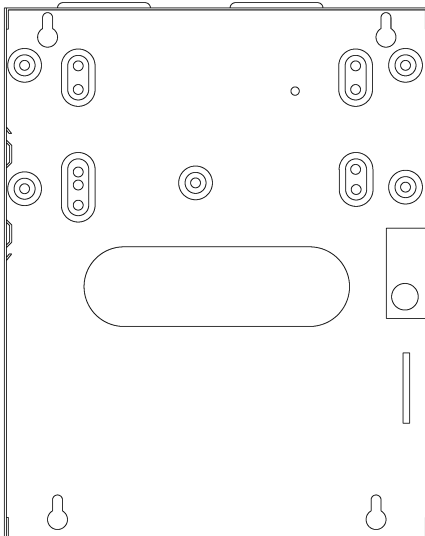

Old Metal Box

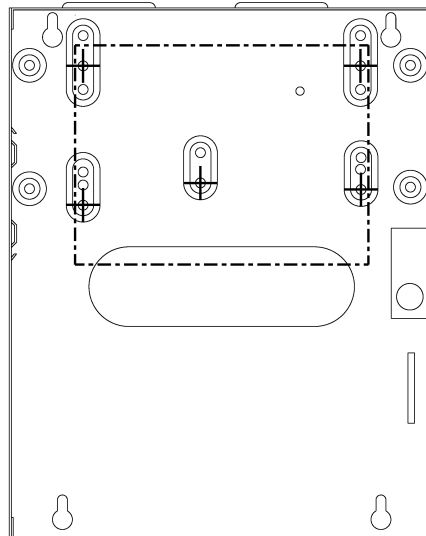

SP5500 Compatible Metal Box

If you need specific dimensions, contact Paradox Distributor Support.

## SP6000 11x11" Metal Box Installation

--- = PCB Position

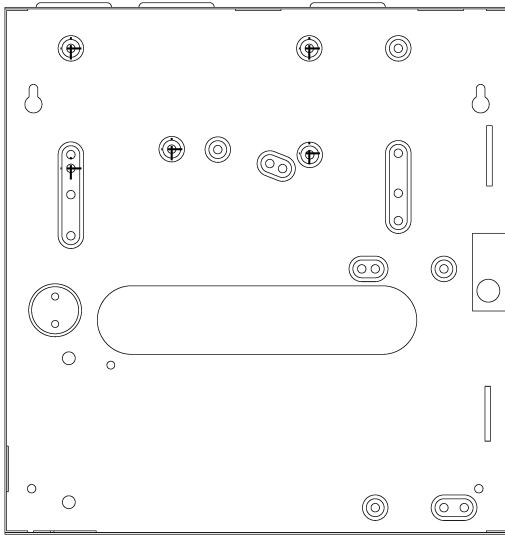

Old Metal Box

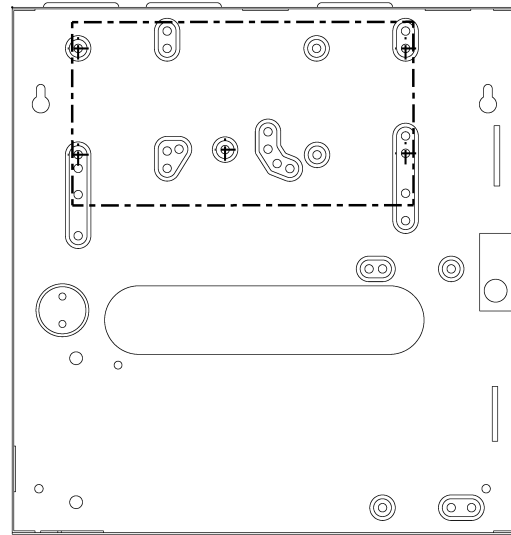

SP6000 Compatible Metal Box

If you need specific dimensions, contact Paradox Distributor Support.

## SP7000 11x11" Metal Box Installation

--- = PCB Position

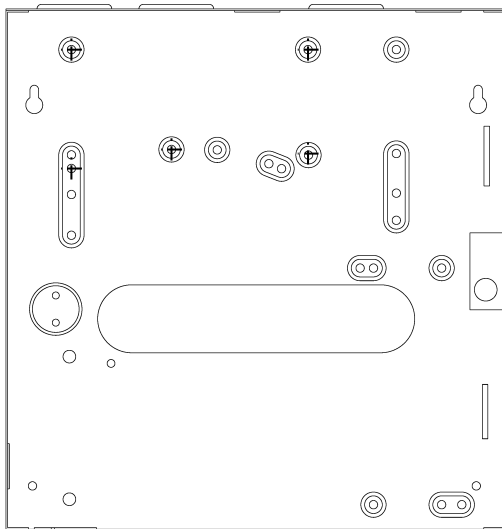

Old Metal Box

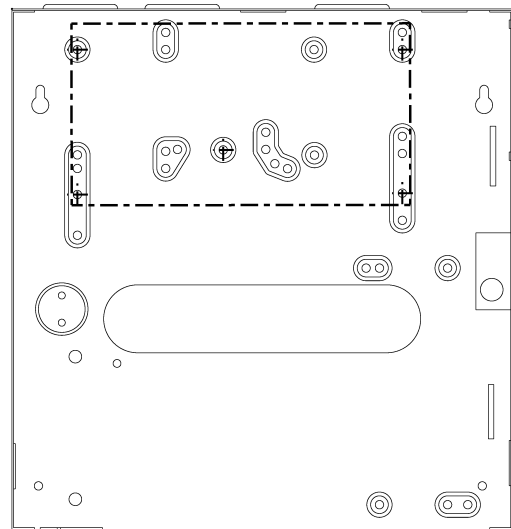

SP7000 Compatible Metal Box

If you need specific dimensions, contact Paradox Distributor Support.

# Trouble Display

- Press the **[TBL]** key to view the Trouble Display. Please note that the keypad can be programmed to emit a beep every 5 seconds whenever a new trouble condition has occurred. Press the **[TBL]** key to stop the beeping.
- To view the sub-menu, press the corresponding key in the main menu.

Main Menu Trouble	Sub-Menu Trouble Menu
[1] Wireless zone low battery	[1] to [32] Zones in low battery
[2] Power trouble	[1] Low/No battery on the control panel [2] AC failure on control panel [3] Auxiliary overload on control panel [4] Wireless keypad AC failure [5] Wireless keypad battery failure [6] Wireless repeater AC failure [7] Wireless repeater battery failure
[3] Bell trouble	[1] Bell disconnect on control panel [2] Bell overload on control panel
[4] Communication trouble	[1] Telephone Line Monitoring on control panel [2] Fail to communicate on Monitoring Telephone 1 on control panel [3] Fail to communicate on Monitoring Telephone 2 on control panel [4] Fail to communicate on pager telephone on control panel [5] Fail to communicate on voice telephone on control panel [6] Fail to communicate with PC on control panel
[5] Tamper and zone wiring failure	[1] to [32] Zones in tamper and zone wiring failure
[6] Module tamper trouble	[1] MG-2WPGM [2] Keypad bus [3] ZX8 bus module [4] RTX3 bus module [5] Wireless keypad
[7] Fire loop trouble	[1] to [32] Zones in fire loop trouble
[8] Timer loss	
[9] Wireless zone supervision loss	[1] to [32] Zones in supervision lost [STAY] RF interference trouble
[0 (10)] or [10] Module supervision loss	[1] MG-2WPGM [2] Keypad bus (Panel reset will not clear this trouble, clear it in section [955]) [3] ZX8 bus module [4] RTX3 bus module [5] Wireless keypad supervision failure [6] Wireless repeater supervision failure
[16] Keypad fault (MG32LED/MG32LRF only)	
[SLEEP] Keypad fault (MG10LEDV/H only)	

## Installer Function Keys

To access the Installer Function keys, press:

**[ENTER]+[INSTALLER CODE] + [MEM]** = *Test Report*: Send the "Test Report" report code programmed in section [840] (page 34) to the monitoring station.

**[ENTER]+[INSTALLER CODE] + [STAY]** = *Cancel Communication*: Cancels all communication with the WinLoad software or with the monitoring station until the next reportable event.

**[ENTER]+[INSTALLER CODE] + [SLEEP]** = *Answer WinLoad Software*: Will force the console to answer an incoming call from the monitoring station that is using the WinLoad software.

**[ENTER]+[INSTALLER CODE] + [BYP]** = *Call WinLoad Software*: Will dial the PC telephone number programmed in section [915] (page 36) in order to initiate communication with a computer using the WinLoad software.

**[ENTER]+[INSTALLER CODE] + [TBL]** = *Installer Test Mode*: The installer test mode will allow you to perform walk tests where the siren will squawk to indicate opened zones. Press the **[TBL]** key again to exit.



# Connecting to WinLoad

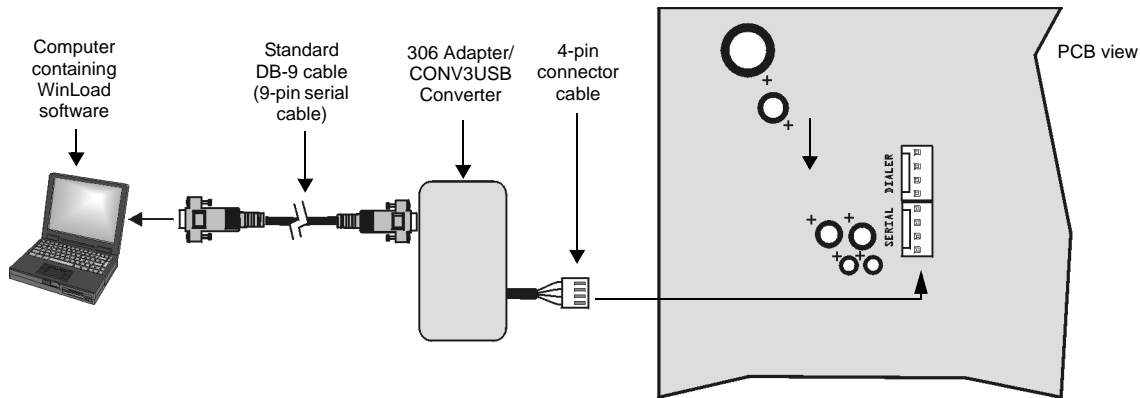

## Updating Firmware Using WinLoad

To update your system firmware:

1. Connect the product to your computer using a 306USB Direct Connect Interface or CONV3USB Converter.
2. Start WinLoad Installer Upload/Download Software.
3. Click the **In-field Programmer** button. 
4. Verify the product information located in the In-Field Firmware Programmer window.  
If the firmware programmer does not automatically detect your control panel, click the **Com port settings** button and select the correct Com port. Then click the **Refresh Product Info** button to connect with the panel.
5. To check for new updates, click the **Download Firmware from the web** button.
6. From the Select Firmware drop-down box, select the firmware version you wish to install.  
**or**  
If you have already downloaded the .pef file from paradox.com, click the [...] button and select the location of the .pef file.
7. Click the **Update product firmware** button.  
*When the download process finishes, the update is complete.*

# MG5000 PCB Layout

Used for In-Field Firmware upgrade through a 306USB Direct Connect Interface. See Connecting to WinLoad on page 49 for details.

Coming soon: VDMP3 plug-in voice module for voice reporting

Press and hold the RESET button for five seconds. The STATUS LED will start flashing. Within 2 seconds of this flashing, press the reset switch again. The panel will reset to default and restart.

Four pin connector can be used for quick installation of a MG5000 keypad.



Refer to AC Power & Backup Battery Connections on page 44.

The "BELL" output will shutdown if the current exceeds 3A.

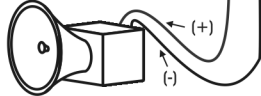

### Connection for Self-Contained Bell/Siren

**!** The sum of the current drawn from the BELL and AUX must be limited to 1.3A (40VA transformer strongly recommended). Exceeding this limit will overload the panel power supply and lead to complete system shutdown.

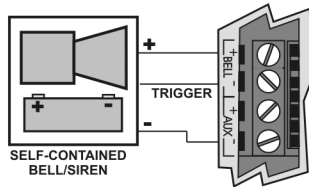

**Charge LED:**  
Charging and Battery test LED

**"STATUS" LED:**  
Flash once every second = Normal  
Flashes ON 1 second and OFF 1 second = Any trouble  
Always ON = Panel is using phone line  
Fast flash 6 seconds after power up = Installer lock enabled

**"RX" & "TX" LED:**  
Flashes quickly when receiving or transmitting RF signals from wireless devices.

**!** Do not cut, bend or alter the antennas and ensure that electrical wires do not cross over the antennae, as this may affect signal reception.

**!** Disconnect telephone line before servicing.

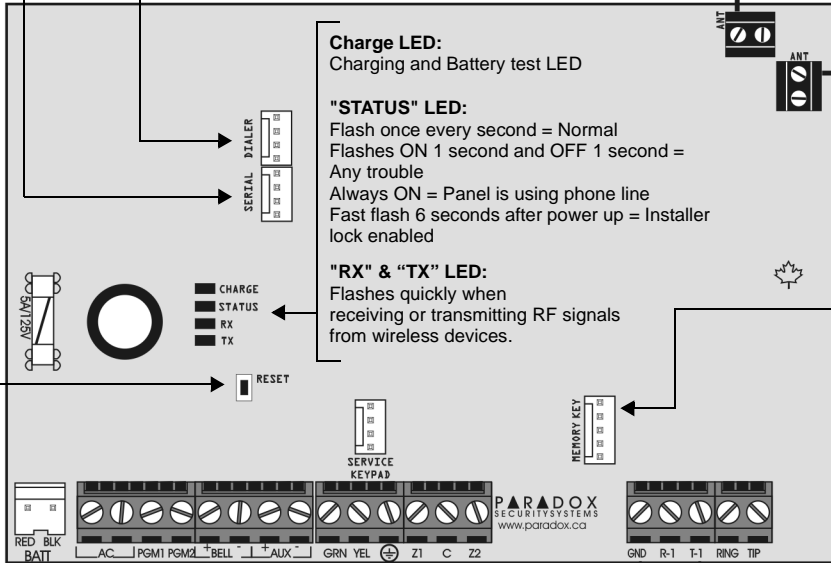

Refer to Single Zone Inputs on page 42

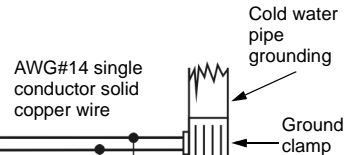

**!** To provide maximum lightning protection we strongly recommend having separate earth connections for the dialer and zone ground terminals.

**!** Max. amount of keypads = 15 keypads  
Max. current = 700 mA  
Max. distance of keypad from panel = 76m (250 feet)  
Max. total run of wire = 230m (750 feet)

### AUX Power

Refer to transformer requirements on page 44 for Aux. Power Output. To connect additional wiring to auxiliary power, use the red (+) and black (-) keypad connectors. Auxiliary power will shut down if current exceeds 1.1A. If the auxiliary output is overloaded and is shut down, you must disconnect all loads from the output for at least 10 seconds before reconnecting any load back to the auxiliary output.

**!** This equipment must be installed and maintained by qualified service personnel only. For UL and C-UL warnings, refer to the UL and C-UL Warnings section at the back of the Reference & Installation Manual.

For the keypad's zone configurations, refer to the **Installer Quick Menu**. If EOL is enabled: see section [706] option [2]. Also refer to Keypad Zone Connections on page 42.

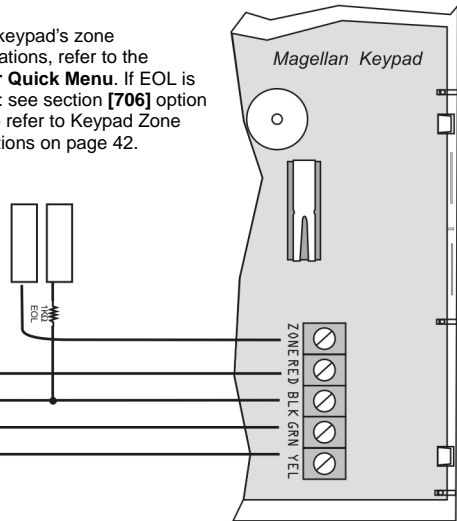

# MG5050 PCB Layout

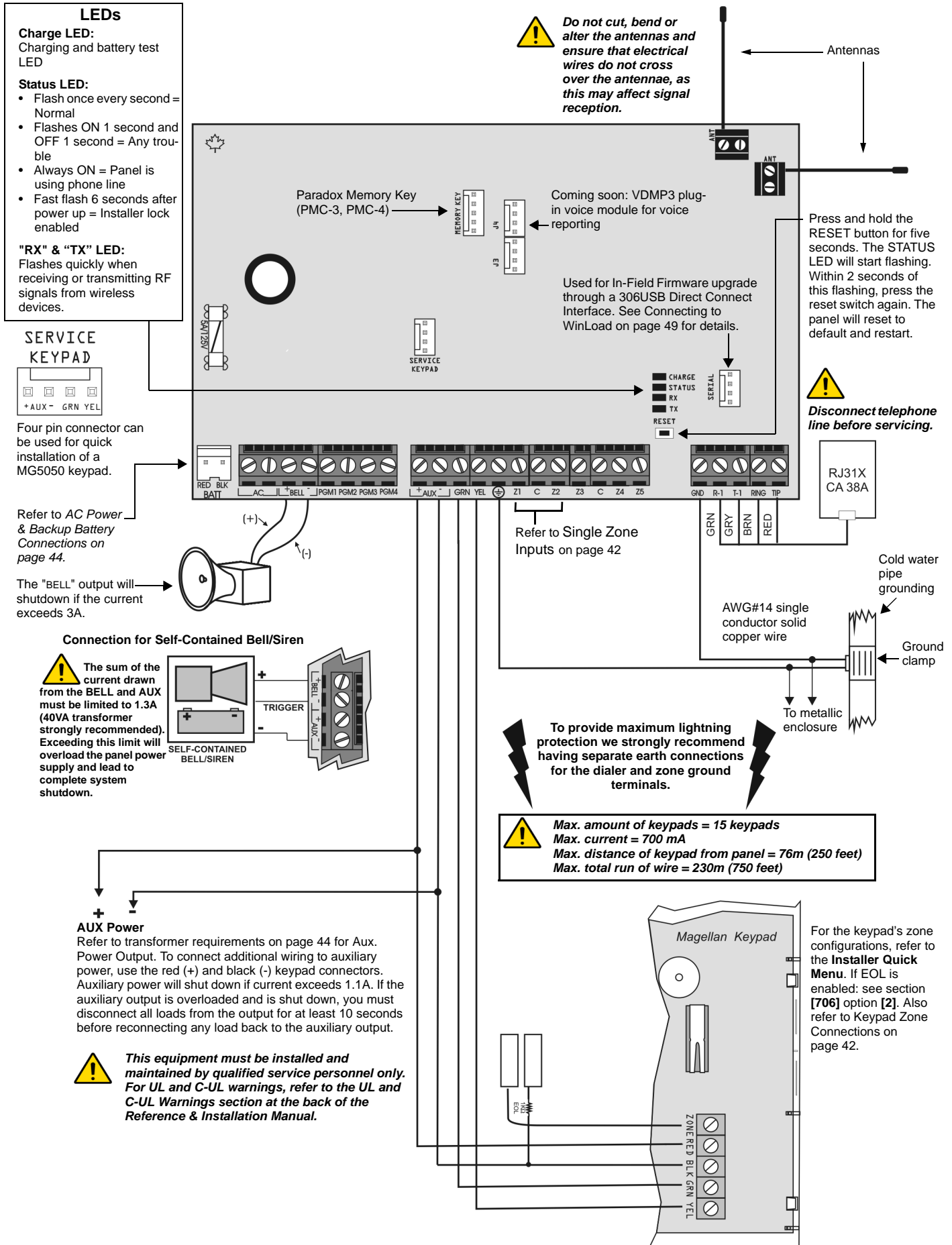

# SP5500 PCB Layout

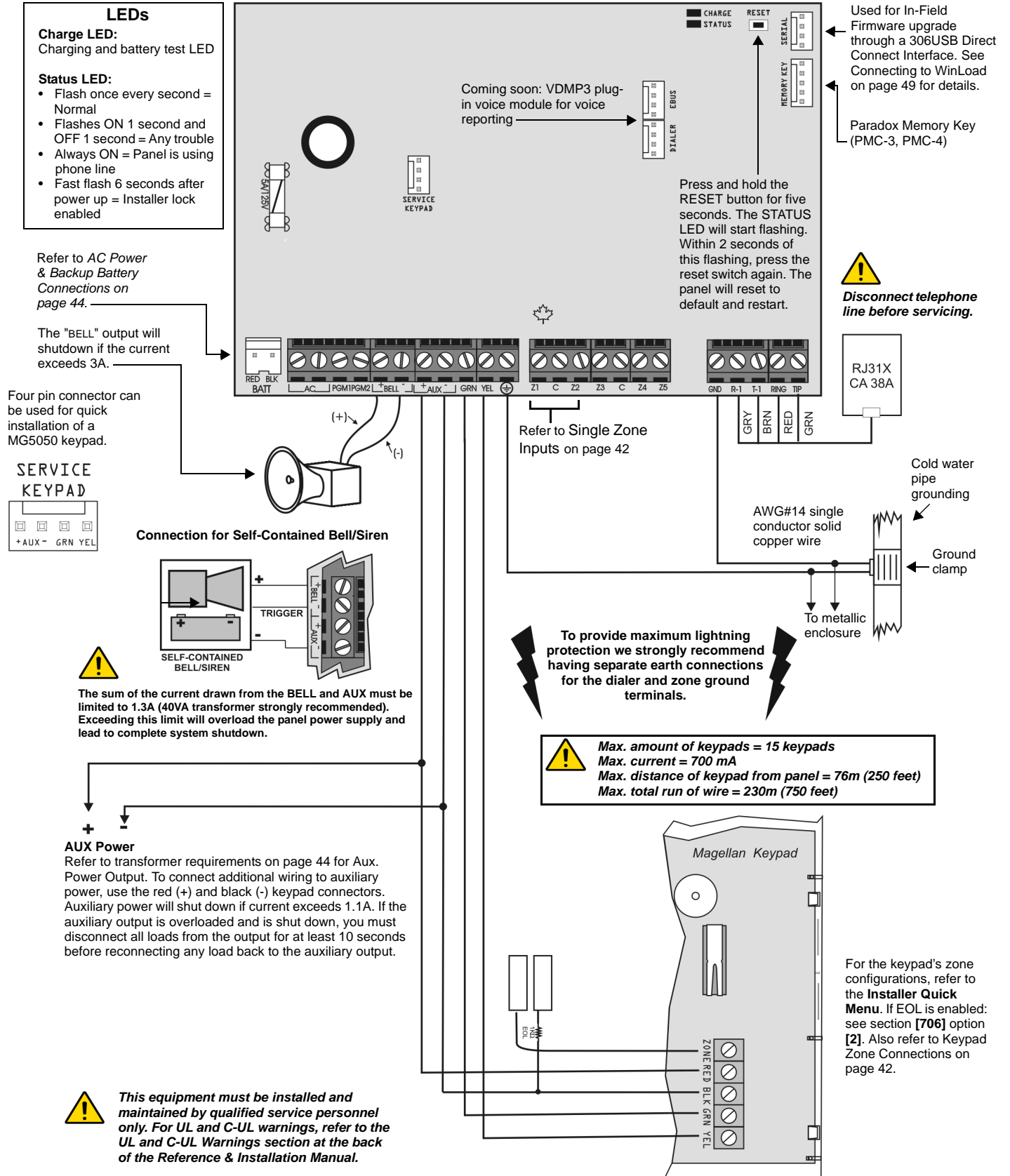

# SP6000 PCB Layout

**LEDs**

**Charge LED:**  
Charging and battery test LED

**Status LED:**

- Flash once every second = Normal
- Flashes ON 1 second and OFF 1 second = Any trouble
- Always ON = Panel is using phone line
- Fast flash 6 seconds after power up = Installer lock enabled

Used for In-Field Firmware upgrade through a 306USB Direct Connect Interface. See Connecting to WinLoad on page 49 for details.

Four pin connector can be used for quick installation of a SP6000 keypad.

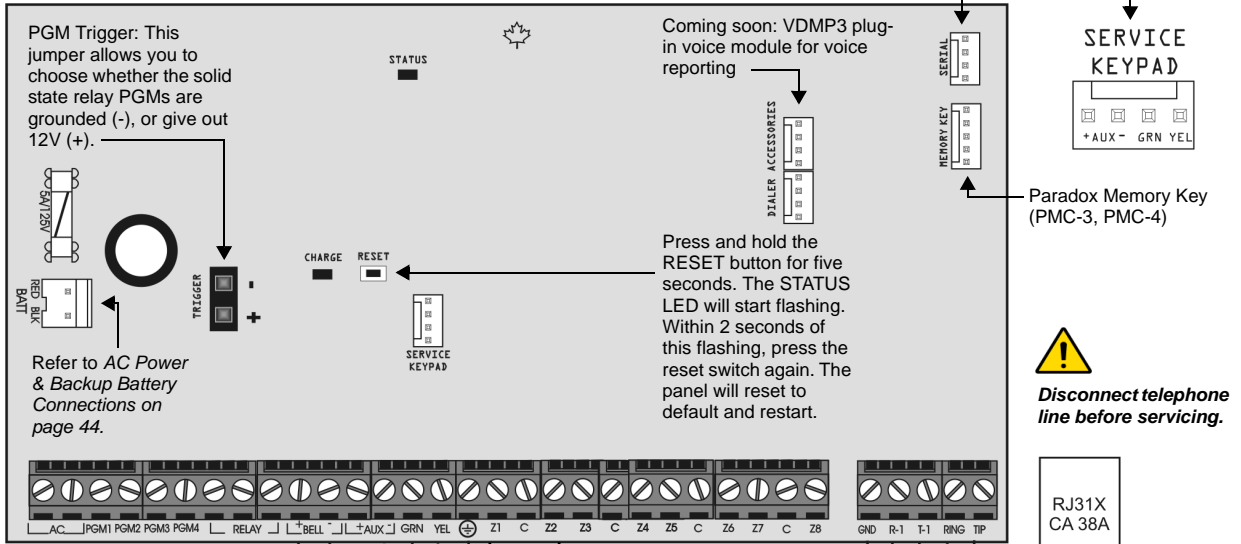

Refer to AC Power & Backup Battery Connections on page 44.

Press and hold the RESET button for five seconds. The STATUS LED will start flashing. Within 2 seconds of this flashing, press the reset switch again. The panel will reset to default and restart.

**Disconnect telephone line before servicing.**

The "BELL" output will shutdown if the current exceeds 3A.

Refer to Single Zone Inputs on page 42

**AUX Power**

Refer to transformer requirements on page 44 for Aux. Power Output. To connect additional wiring to auxiliary power, use the red (+) and black (-) keypad connectors. Auxiliary power will shut down if current exceeds 1.1A. If the auxiliary output is overloaded and is shut down, you must disconnect all loads from the output for at least 10 seconds before reconnecting any load back to the auxiliary output.

**Connection for Self-Contained Bell/Siren**

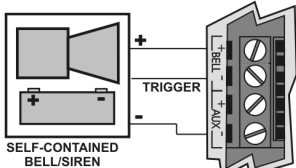

**The sum of the current drawn from the BELL and AUX must be limited to 1.3A (40VA transformer strongly recommended). Exceeding this limit will overload the panel power supply and lead to complete system shutdown.**

To provide maximum lightning protection we strongly recommend having separate earth connections for the dialer and zone ground terminals.

- Max. amount of keypads = 15 keypads**
- Max. current = 700 mA**
- Max. distance of keypad from panel = 76m (250 feet)**
- Max. total run of wire = 230m (750 feet)**

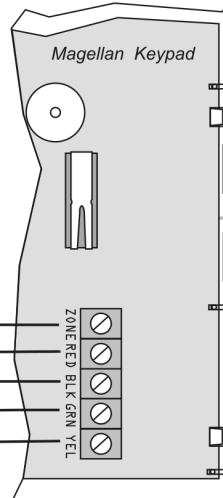
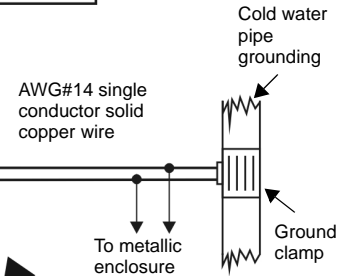

For the keypad's zone configurations, refer to the **Installer Quick Menu**. If EOL is enabled: see section [706] option [2]. Also refer to Keypad Zone Connections on page 42.

**This equipment must be installed and maintained by qualified service personnel only. For UL and C-UL warnings, refer to the UL and C-UL Warnings section at the back of the Reference & Installation Manual.**

# SP7000 PCB Layout

**LEDs**

**Charge LED:**  
Charging and battery test LED

**Status LED:**

- Flash once every second = Normal
- Flashes ON 1 second and OFF 1 second = Any trouble
- Always ON = Panel is using phone line
- Fast flash 6 seconds after power up = Installer lock enabled

Used for In-Field Firmware upgrade through a 306USB Direct Connect Interface. See Connecting to WinLoad on page 49 for details.

Four pin connector can be used for quick installation of a SP7000 keypad.

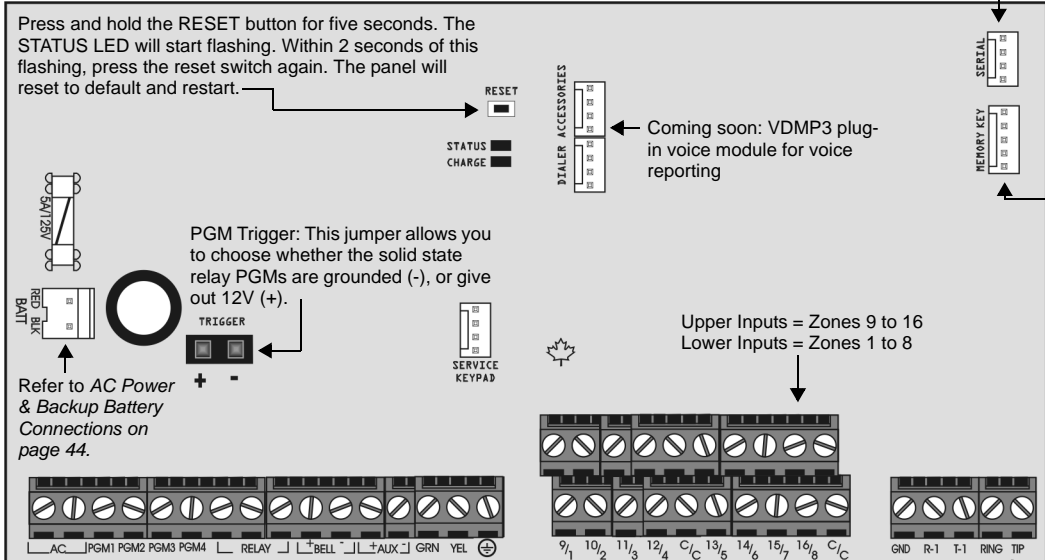

Paradox Memory Key (PMC-3, PMC-4)

**Disconnect telephone line before servicing.**

The "BELL" output will shutdown if the current exceeds 3A.

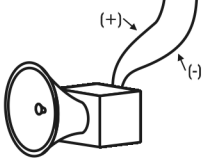

**AUX Power**  
Refer to transformer requirements on page 44 for Aux. Power Output. To connect additional wiring to auxiliary power, use the red (+) and black (-) keypad connectors. Auxiliary power will shut down if current exceeds 1.1A. If the auxiliary output is overloaded and is shut down, you must disconnect all loads from the output for at least 10 seconds before reconnecting any load back to the auxiliary output.

**Connection for Self-Contained Bell/Siren**

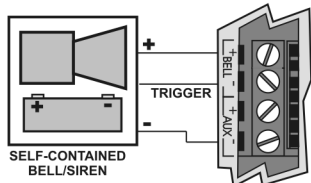

**The sum of the current drawn from the BELL and AUX must be limited to 1.3A (40VA transformer strongly recommended). Exceeding this limit will overload the panel power supply and lead to complete system shutdown.**

**To provide maximum lightning protection we strongly recommend having separate earth connections for the dialer and zone ground terminals.**

- Max. amount of keypads = 15 keypads**
- Max. current = 700 mA**
- Max. distance of keypad from panel = 76m (250 feet)**
- Max. total run of wire = 230m (750 feet)**

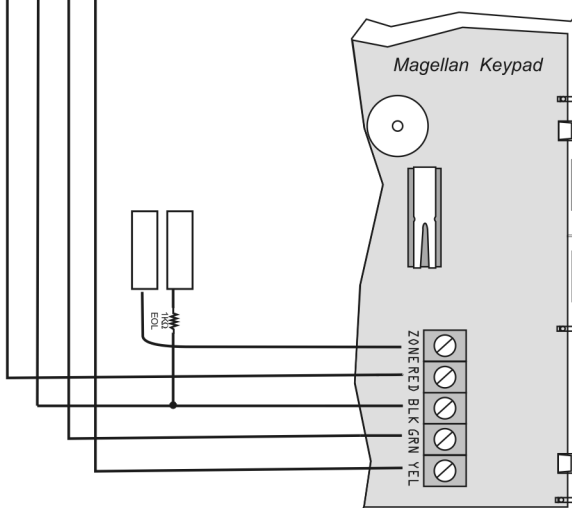
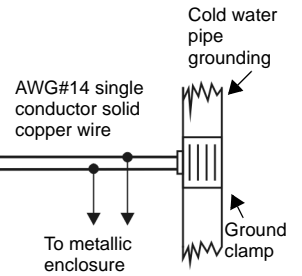

For the keypad's zone configurations, refer to the **Installer Quick Menu**. If EOL is enabled: see section [706] option [2]. Also refer to Keypad Zone Connections on page 42.

**This equipment must be installed and maintained by qualified service personnel only. For UL and C-UL warnings, refer to the UL and C-UL Warnings section at the back of the Reference & Installation Manual.**

## Warranty

Paradox Security Systems Ltd. ("Seller") warrants its products to be free from defects in materials and workmanship under normal use for a period of one year. Except as specifically stated herein, all express or implied warranties whatsoever, statutory or otherwise, including without limitation, any implied warranty of merchantability and fitness for a particular purpose, are expressly excluded. Because Seller does not install or connect the products and because the products may be used in conjunction with products not manufactured by Seller, Seller cannot guarantee the performance of the security system and shall not be responsible for circumstances resulting from the product's inability to operate. Seller obligation and liability under this warranty is expressly limited to repairing or replacing, at Seller's option, any product not meeting the specifications. Returns must include proof of purchase and be within the warranty period. In no event shall the Seller be liable to the buyer or any other person for any loss or damages whether direct or indirect or consequential or incidental, including without limitation, any damages for lost profits, stolen goods, or claims by any other party, caused by defective goods or otherwise arising from the improper, incorrect or otherwise faulty installation or use of the merchandise sold. Notwithstanding the preceding paragraph, the Seller's maximum liability will be strictly limited to the purchase price of the defective product. Your use of this product signifies your acceptance of this warranty. BEWARE: Dealers, installers and/or others selling the product are not authorized to modify this warranty or make additional warranties that are binding on the Seller.

## Limitations of Alarm Systems:

It must be understood that while your Paradox alarm system is highly advanced and secure, it does not offer any guaranteed protection against burglary, fire or other emergency (fire and emergency options are only available on certain Paradox models). This is due to a number of reasons, including but not limited to inadequate or improper installation/positioning, sensor limitations, battery performance, wireless signal interruption, inadequate maintenance or the potential for the system or telephone lines to be compromised or circumvented. As a result, Paradox does not represent that the alarm system will prevent personal injury or property damage, or in all cases provide adequate warning or protection.

Your security system should therefore be considered as one of many tools available to reduce risk and/or damage of burglary, fire or other emergencies, such other tools include but are not limited to insurance coverage, fire prevention and extinguish devices, and sprinkler systems.

We also strongly recommend that you regularly maintain your security systems and stay aware of new and improved Paradox products and developments.

## TBR-21: In order to comply with TBR-21, standard force dialing must be enabled.

## UL AND ULC WARNINGS

This equipment is UL listed in accordance with standard UL1023 (Household Burglar -- Alarm Systems Units), standard UL985 (Household Fire Warning Units) and standard UL1635 (Digital Alarm Communicator System Units). This equipment has the capability of being programmed with features not verified for use in UL installations. To stay within these standards, the installer should use the following guidelines when configuring the system:

- All components of the system should be UL listed for the intended application.
- If used for "Fire" detection, the installer should refer to NFPA Standards #72, Chapter 2. In addition, once installation is complete, the local fire authority must be notified of the installation.
- WARNING: This equipment must be installed and maintained by qualified service personnel only
- This equipment must be verified by a qualified technician once every three years.
- All keypads must use an anti-tamper switch.
- Do not bypass fire zones.
- Maximum allowed entry delay is 45 seconds.
- Maximum allowed exit delay is 60 seconds.
- Minimum 4 minutes for bell cut-off time.
- The following features do not comply with UL requirements: Bypass Recall and Auto Trouble Shutdown.
- Do not connect the primary indicating device to a relay. The installer must use the bell output.
- To comply with UL985, the auxiliary power output should not exceed 200mA.
- Do not connect the zone ground terminal with UL Listed products.
- The metallic enclosure must be grounded to the cold water pipe.
- All outputs are Class 2 or power-limited, except for the battery terminal. The Class 2 and power-limited fire alarm circuits shall be installed using CL3, CL3R, CL3P, or substitute cable permitted by the National Electrical Code, ANSI/NFPA 70.
- EOL resistor part #2011002000
- **For UL Installations:** Universal UB1640W 16.5VAC min 40VA
- All outputs are rated from 11.3Vdc to 12.7Vdc
- 12Vdc 4Ah rechargeable acid/lead or gel cell backup battery (YUASA model #NP7-12 recommended) for residential use. Use a 7Ah battery to comply with fire requirements.
- Wheelock 46T-12 siren

## Legal

© 2004-2007 Paradox Security Systems Ltd. All rights reserved. Specifications may change without prior notice. One or more of the following US patents may apply: 7046142, 6215399, 6111256, 6104319, 5920259, 5886632, 5721542, 5287111, 5119069, 5077549 and RE39406. Canadian and international patents may also apply. Magellan and Spectra are trademarks or registered trademarks of Paradox Security Systems Ltd. or its affiliates in Canada, the United States and/or other countries.

**P ▲ R ▲ D O X<sup>®</sup>**  
**S E C U R I T Y S Y S T E M S**  
[paradox.com](http://paradox.com)

Printed in Canada - 03/2007

MGSP-EP08